

# Reliable®

## Model DDX Deluge Valves 4" (100 mm), 6" (150 mm) and 165 mm Sizes

### Features

1. Differential-type, lightweight, dependable construction.
2. Easily trimmed for releasing by:
  - Manual pull stations
  - Wet pilot sprinklers
  - Dry pilot actuators
  - Solenoid valves
3. Drop in seat & clapper assembly simplifies maintenance.
4. Bronze seat with O-ring seals resists corrosion and leakage.
5. Pressure-actuated clapper facing provides dependable seal.
6. Reset externally. Cover removal is not required.
7. Grooved inlet and outlet connections.
8. Drain valve to drain standing water column.
9. Valve latches in open position. No pressure-operated relief valve is required.
10. Pressure rating of 250 psi (17,2 bar).

### Listings & Approvals

(Only when used with Reliable's Trim Sets.)

1. Listed by Underwriters Laboratories, Inc. and UL certified for Canada (cULus).
2. Certified by Factory Mutual Approvals (FM).
3. NYC MEA 258-93-E

#### REAR VIEW OF MODEL DDX DELUGE VALVE

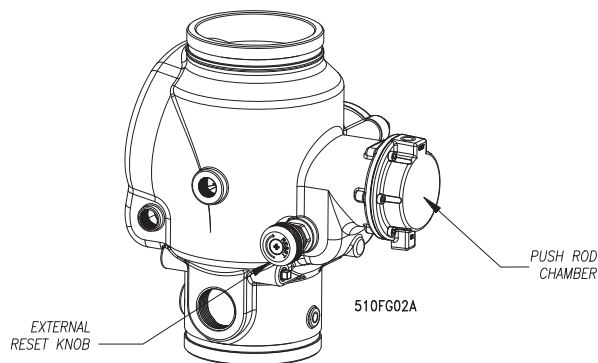

PUSH INWARD AND ROTATE KNOB CLOCKWISE TO RESET CLAPPER.  
DO SO ONLY WHEN PUSH ROD CHAMBER IS UNPRESSURIZED (0 PSIG).



The Reliable Model DDX Deluge Valve is a hydraulically operated, differential-type valve used to control the water supply to a deluge or preaction system. Deluge systems use open sprinklers or nozzles as discharge outlets in the fire area, while preaction systems use closed sprinklers or nozzles. Both systems use separate detection devices to control the operation of the Deluge Valve. Three simple trim arrangements allow for actuation of the Reliable Model DDX Deluge Valve by utilizing manual, hydraulic, pneumatic, or electrical devices. These devices include break glass stations, wet pilot sprinklers, dry pilot sprinklers, thermal detectors, and smoke detectors.

The Reliable Model DDX Deluge Valve can be reset externally, without cover removal. This is accomplished by pushing in and turning the external reset knob at the rear of the Deluge Valve (see Fig. 2).

### Valve Operation

The Reliable Model DDX Deluge Valve is shown in both closed and open positions in Fig. 3. In the closed position, the supply pressure acts on the underside of the clapper and also on the push rod through the push rod chamber's inlet restriction. The resultant force due to the supply pressure acting on the push rod is multiplied by the mechanical advantage of the lever and is more than sufficient to hold the clapper closed against normal supply pressure surges.

When a fire is detected, a releasing device vents the push rod chamber to atmosphere through the chamber's outlet. Since the pressure cannot be replenished through the inlet restriction as rapidly as it is vented, the push rod chamber pressure falls instantaneously. When the push rod chamber pressure approaches approximately one-third of the supply pressure, the upward force of the supply pressure acting beneath the clapper overcomes the lever-applied force thereby opening the clapper.

Once the clapper has opened, the lever acts as a latch, preventing the clapper from returning to the closed position. Water from the supply flows through the Deluge Valve into the system piping. Water also flows through the Deluge Valve's alarm outlet to the alarm devices.

After system shutdown, resetting the Model DDX Deluge Valve is quite simple. Doing so only requires pushing in and turning the reset knob at the rear of the valve (see Fig.2). The external reset feature of the Model DDX Deluge Valve provides a means for simple, economical system testing, which is one essential facet of a good maintenance program. The external reset feature does not, however, eliminate another important facet of good maintenance, namely, periodic cleaning and inspection of the internal valve parts.

In the event that water builds up inside the valve due to condensate from the air supply system, or water left inside from valve system testing, a drain is available for venting. After closing the main supply valve, a small valve over the drain cup can be opened slightly until the water inside the valve body and the main pipe column has drained.

Whenever ambient temperature conditions are high, the water temperature in the Model DDX Deluge Valve's pushrod chamber could possibly increase, thereby increasing the pres-

sure in the chamber to values exceeding the rated pressure of the system. In an indoor installation where standard room temperatures are exceeded, a pressure relief kit may be needed. Pressure relief kit, P/N 6503050001, can be installed into the pushrod chamber's releasing line to limit the pressure to 175 psi (12,1 bar).

Reliable Model DDX Deluge Valves with associated trim sizes 4" (100 mm), 6" (150mm) and 165mm, are rated for use at a minimum water supply pressure of 20 psi (1,4 bar) and a maximum water supply pressure of 250 psi (17,2 bar). Water supplied to the inlet of the valve and to the push rod chamber must be maintained between 40°F (4°C) and 140°F (60°C).

### Detection and Actuation

In general, the Reliable Model DDX Deluge Valve can be released by any Reliable UL Listed or FM Approved device that opens sufficiently to vent the push rod chamber in response to a fire. The releasing device is simply connected to the push rod chamber's outlet. When the releasing device operates and vents the push rod chamber, the Deluge Valve opens.

Typical releasing devices include hydraulic manual emergency stations, Model F1-FTR Fixed Temperature Detectors on wet pilot lines, dry pilot actuators, and solenoid valves. Model F1-FTR Detectors perform both Deluge Valve releasing and fire detection functions with wet pilot lines.

The use of a solenoid valve for Deluge Valve releasing enables various types of electrical fire detection devices to be used. Typical detection devices include electrical emergency pull stations, thermal detectors, and ionization or photoelectric smoke detectors. Electrical detection and releasing equipment used in Supertrol Electrical Systems is described in Bulletins 707 and 708, for both deluge and preaction systems

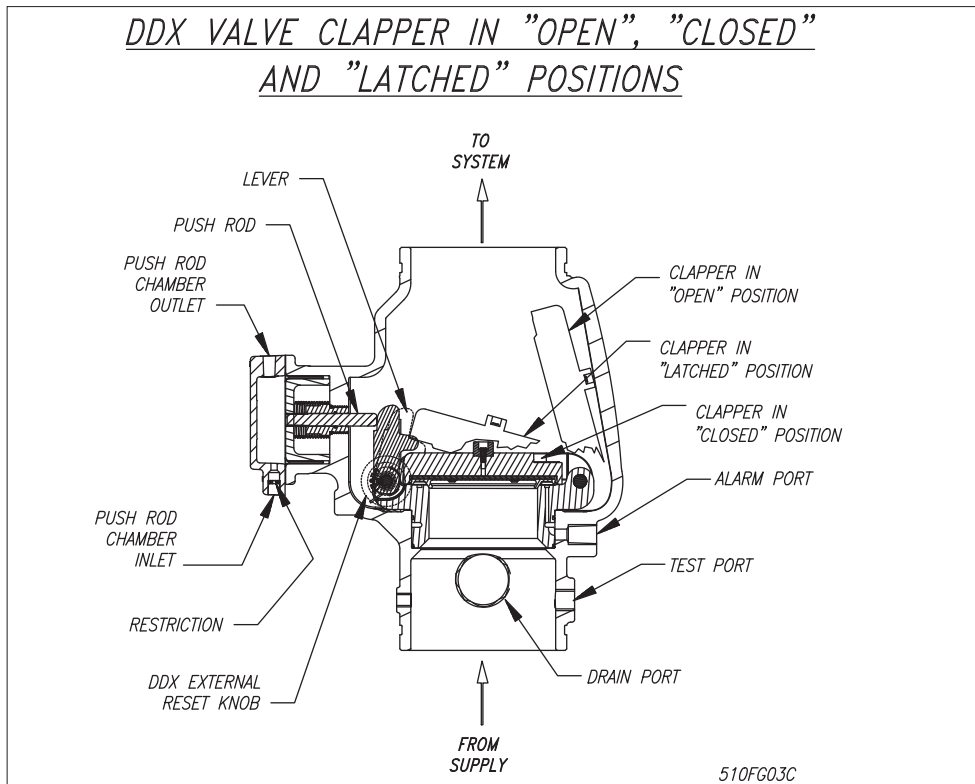

Fig. 3

## Model DDX Deluge Valve Description

- Rated working pressure:  
Valve & System - 250 psi (17,2 bar)
- Factory tested to a hydrostatic pressure of 500 psi (34,5 bar). (Valve only)
- End and trim connections:
  - ANSI/AWWA C606 grooved inlet and outlet

Groove Dimensions				
Valve Size	Outlet Diameter	Groove Diameter	Groove Width	Outlet Face to Groove
4" (100mm)	4.500" (114mm)	4.334" (110mm)	3/8" (10mm)	5/8" (16mm)
6" (150mm)	6.625" (168mm)	6.455" (164mm)		
165mm	6.500" (165mm)	6.330" (161mm)		

- Threaded openings Per ANSI B 2.1
- Valve exterior's color:

Valve Size	Color
4" (100 mm) 6" (150 mm)	Black
165 mm	Red

- Face to face dimensions:
  - 4" (100 mm) — 14" (355 mm)
  - 6" (150 mm) & 165 mm — 16" (406 mm)
- Shipping weight:

Valve Size	Weight
4" (100 mm) 6" (150 mm) & 165mm	64 lb. (29 kg) 95 lb. (43 kg)

- Friction loss (Expressed in equivalent length of Schedule 40 pipe, based on Hazen & Williams formula with C=120 and a flow velocity of 15ft/sec (4.6 m/sec)):

Valve Size	Equivalent Length
4" (100mm) 6" (150mm) & 165mm	14' (4.27 m) 29.4' (9 m)

- Installation position: Vertical

### Trim Descriptions

The trims for the Reliable Model DDX Deluge Valve are arranged for rapid, easy, and compact attachment, and serve as connection points to Reliable Model C Mechanical Alarms and other devices.

The available Model DDX Deluge Valve trim sets are:

- Wet Pilot Trim
- Dry Pilot Trim
- Electric Actuation Trim,

The Wet Pilot Trim (see Fig. 4) is used when wet pilot sprinklers or hydraulic manual emergency pull boxes are used for detection and releasing. This trim set provides a two-inch main drain, alarm test, supply pressure gauge, push rod chamber pressure gauge, push rod chamber supply connections, Model B Hydraulic Manual Emergency Station, and a connection for releasing devices.

The Dry Pilot Trim (see Fig. 5) is used when dry pilot sprinklers are used as the fire detection means. This trim set includes the Model LP Dry Pilot Line Actuator, air and water pressure gauges, low air pressure switch (for Dry Pilot Line), air pressure relief valve, connections for the air supply and pilot sprinkler lines, a two-inch main drain, alarm test, push rod chamber connections, push rod chamber pressure gauge, and the Model B Hydraulic Manual Emergency Station. Table A provides the recommended air pressure when the dry pilot trim set is used as the actuation means.

**Table A**

Water Pressure psi (bar)	Pneumatic Pressure to be Pumped into Sprinkler System, psi (bar)		
	Maximum	Not Less Than	Not More Than
20 (1,4)	10 (0,7)	14 (0,9)	
50 (3,4)	12 (0,8)	16 (1,1)	
75 (5,2)	13 (0,9)	17 (1,2)	
100 (6,9)	15 (1,0)	19 (1,3)	
125 (8,6)	16 (1,1)	20 (1,4)	
150 (10,3)	17 (1,2)	21 (1,4)	
175 (12,1)	18 (1,2)	22 (1,5)	
200 (13,8)	19 (1,3)	23 (1,6)	
225 (15,5)	21 (1,5)	25 (1,7)	
250 (17,2)	22 (1,5)	26 (1,8)	

**Note:** During system set-up, a higher pneumatic pressure may be required in order to properly set the Model LP Dry Valve Actuator

The Electric Actuation Trim (see Fig. 6) is used when electric detection and releasing are desired. This trim set includes a solenoid valve (175 psi (12,1 bar) or 250 psi (17, 2 bar) rated), two-inch main drain, alarm test supply pressure gauge, push rod chamber supply connections, push rod chamber pressure gauge, and the Model B Hydraulic Manual Emergency Station are also included. Detailed description of electrical operation can be found in Bulletins 707 and 708.

The Model B Hydraulic Manual Emergency Station is a standard item in all trim sets. However, the Model A Hydraulic Manual Emergency Station, described in Bulletin 506, is also available as an option.

All Model DDX Deluge Valves are listed by Underwriters Laboratories, Inc, and certified by UL for Canada (cULus) and certified by Factory Mutual Approvals, only when used with the valve manufacturer's trim sets.

# WET PILOT LINE DELUGE TRIM

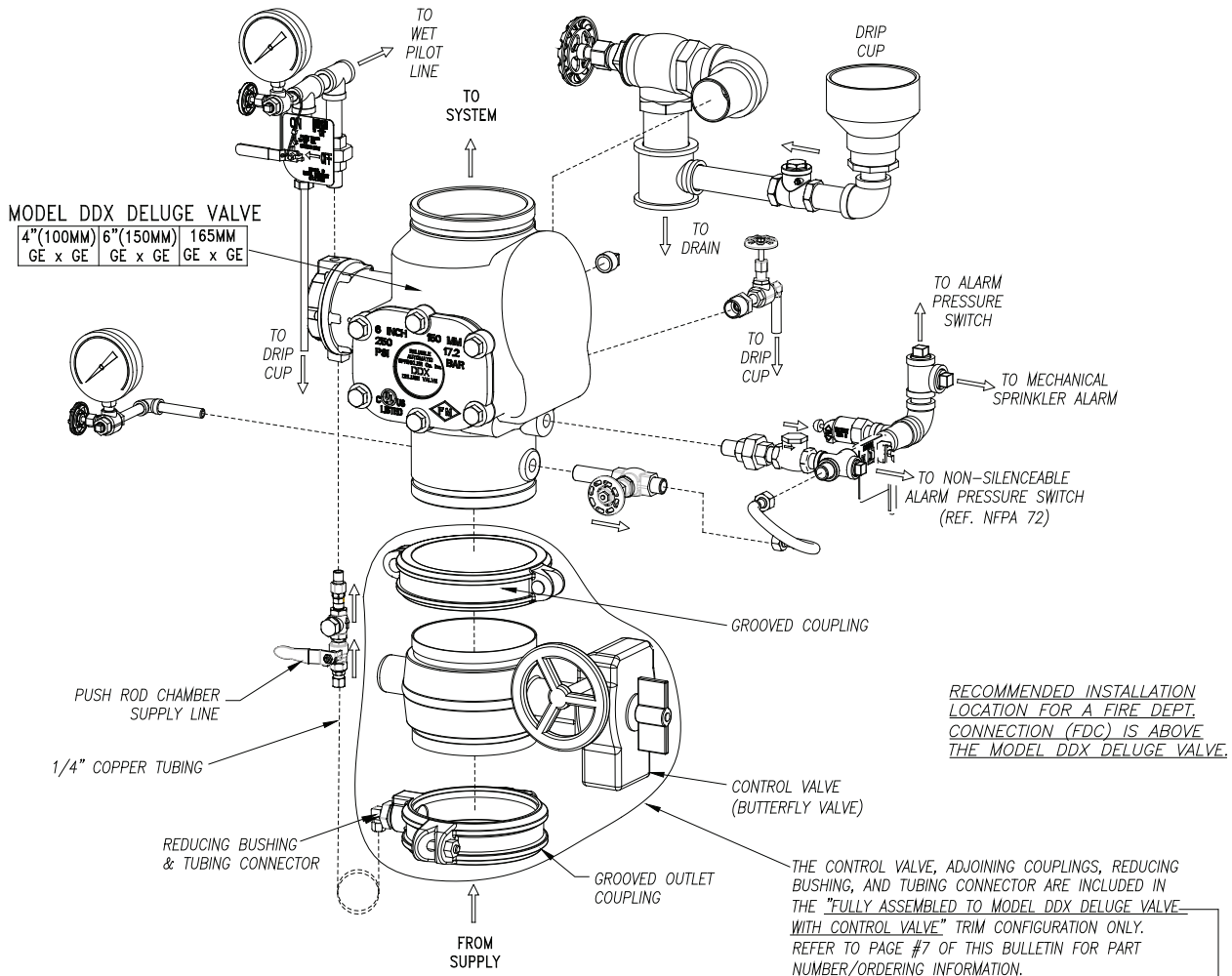

- |  |   |
|--|---|
| <p>AVAILABLE TRIM CONFIGURATIONS:</p> <p>*NOT AVAILABLE WITH 166MM MODEL DDX VALVE</p> | <ol style="list-style-type: none"> <li>1) INDIVIDUAL PARTS (MODEL DDX DELUGE VALVE SOLD SEPARATELY)</li> <li>2) SEGMENTALLY ASSEMBLED (MODEL DDX DELUGE VALVE SOLD SEPARATELY)</li> <li>*3) FULLY ASSEMBLED TO MODEL DDX DELUGE VALVE WITH CONTROL VALVE</li> <li>4) FULLY ASSEMBLED TO MODEL DDX DELUGE VALVE WITHOUT CONTROL VALVE</li> </ol> |
|--|---|

510FG04E

ALL STEEL COMPONENTS OF THE TRIM ASSEMBLIES ARE GALVANIZED

Fig. 4

# DRY PILOT LINE DELUGE TRIM

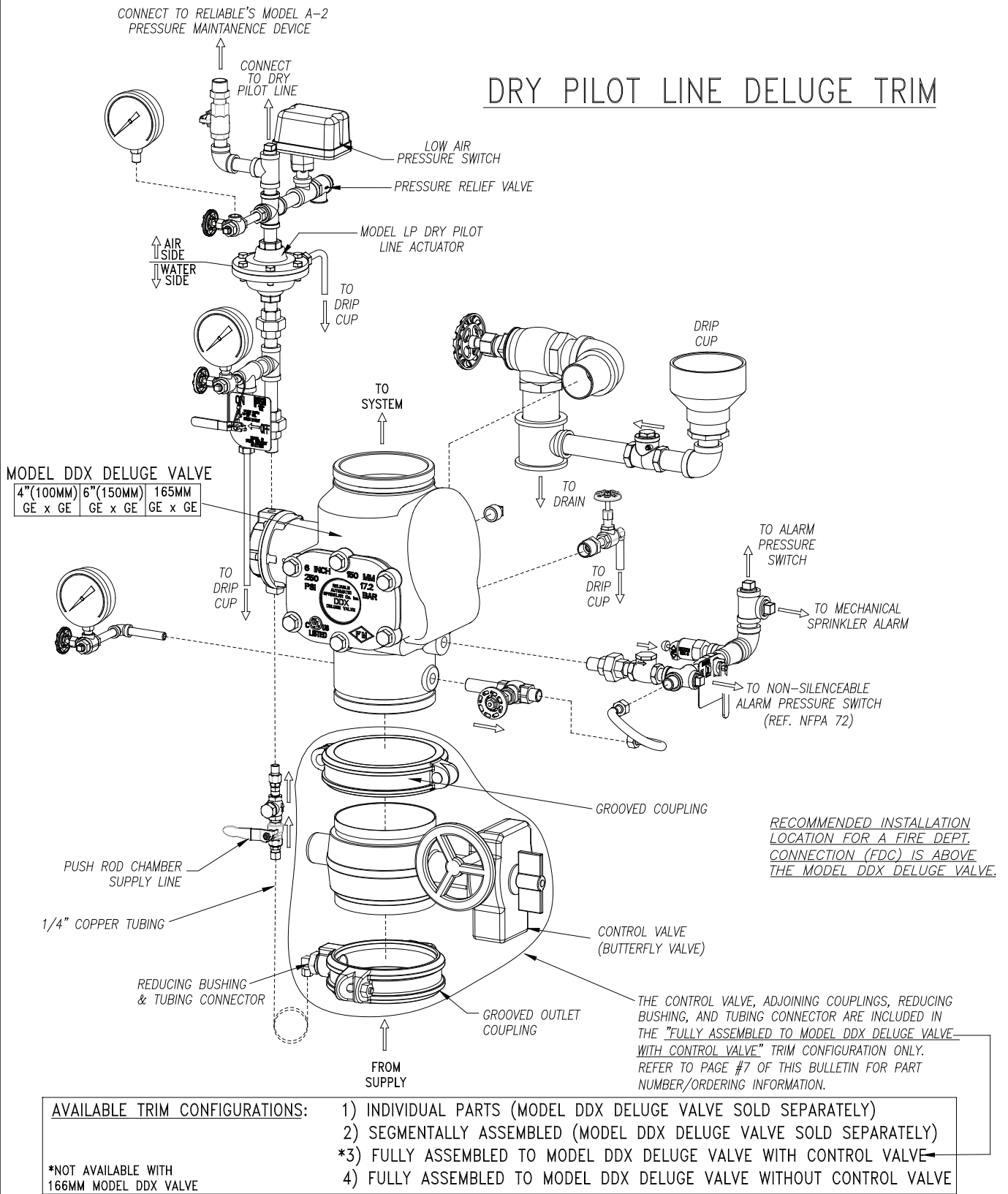

510FG05E

ALL STEEL COMPONENTS OF THE TRIM ASSEMBLIES ARE GALVANIZED

Fig. 5



# ELECTRIC ACTUATION DELUGE TRIM

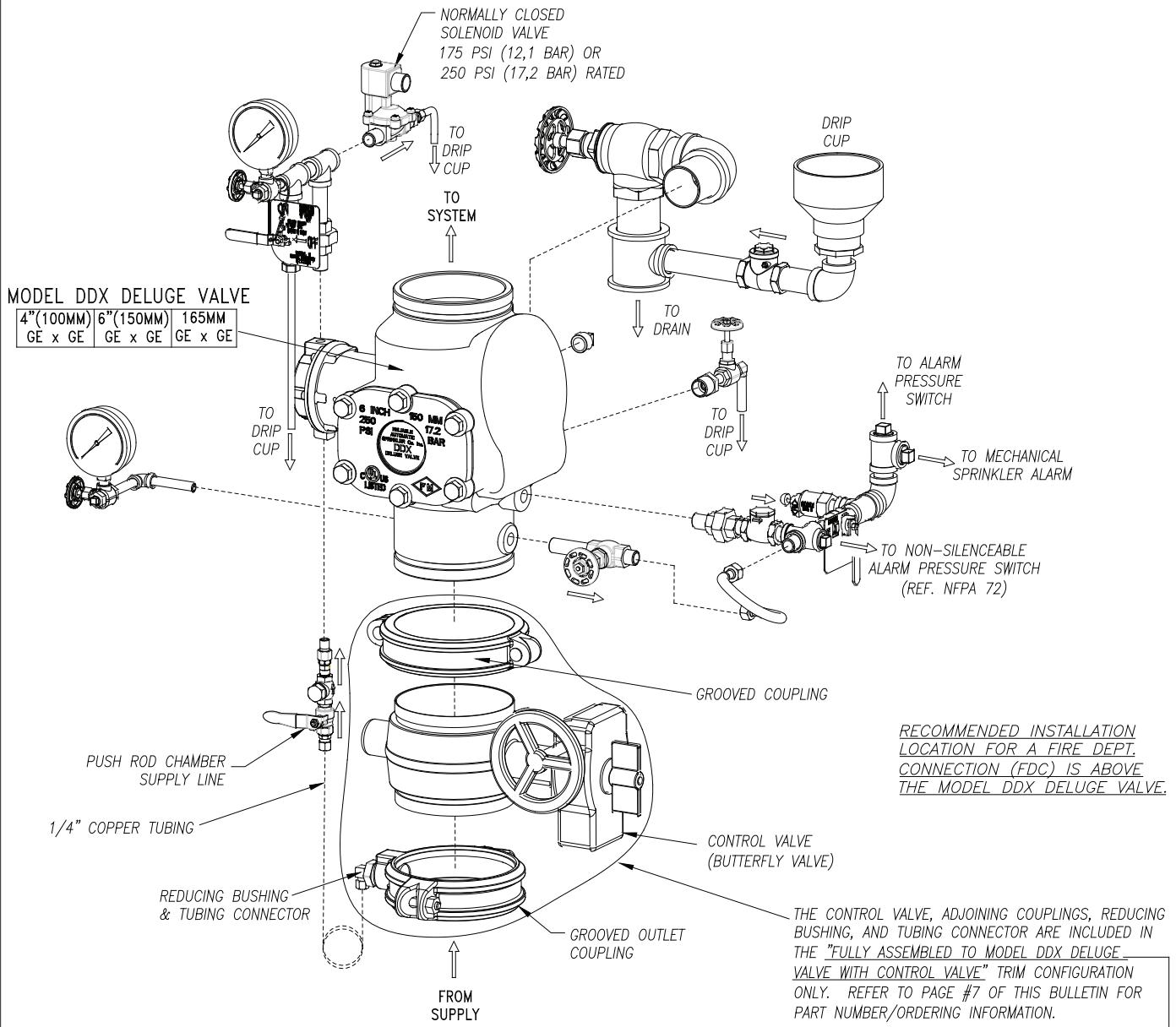

**AVAILABLE TRIM CONFIGURATIONS:**

\*NOT AVAILABLE WITH  
166MM MODEL DDX VALVE

- 1) INDIVIDUAL PARTS (MODEL DDX DELUGE VALVE SOLD SEPARATELY)
- 2) SEGMENTALLY ASSEMBLED (MODEL DDX DELUGE VALVE SOLD SEPARATELY)
- \*3) FULLY ASSEMBLED TO MODEL DDX DELUGE VALVE WITH CONTROL VALVE
- 4) FULLY ASSEMBLED TO MODEL DDX DELUGE VALVE WITHOUT CONTROL VALVE

510FG06E

ALL STEEL COMPONENTS OF THE TRIM ASSEMBLIES ARE GALVANIZED

Fig. 6

## Ordering Information

### Specify:

- **Valve Model & Size** — 4" (100 mm) Model DDX Deluge Valve (P/N 6103040026), 6" (150 mm) Model DDX Deluge Valve (P/N 6103060024), 165mm Model DDX Deluge Valve (P/N 6103060028)
- **Trim** — Wet Pilot Trim, Dry Pilot Trim, or Electric Actuation Trim. Each trim set is available in individual parts, in time-saving, segmentally assembled kit forms, or fully assembled to the Model DDX Deluge Valve with or without a control valve). The Electric Actuation trim is available with a 175 psi (12,1 bar) or 250 psi (17,2 bar) rated solenoid valve.

### Wet Pilot Line Deluge

Trim Configurations	Trim Part Numbers		
	For 4" (100mm) Valve	For 6" (150mm) Valve	For 165mm Valve
Fully Assembled to DDX Valve w/Control Valve	6505040200	6505060200	Not Available
Fully Assembled to DDX Valve w/o Control Valve	6505040201	6505060201	6505065201
Segmentally Assembled (DDX Valve Sold Separately)	6503001003		
Individual Parts (DDX Valve Sold Separately)	6503001002		

### Dry Pilot Line Deluge

	Trim Configurations	Trim Part Numbers		
		For 4" (100 mm) Valve	For 6" (150 mm) Valve	For 165 mm Valve
UL/FM Approved Pressure Switch	Fully Assembled to DDX Valve w/ Control Valve	6505040205	6505060205	Not Available
	Fully Assembled to DDX Valve w/o Control Valve	6505040206	6505060206	6505065206
	Segmentally Assembled (DDX Valve Sold Separately)	6503001108		
	Individual Parts (DDX Valve Sold Separately)	6503001107		
ULC Approved Pressure Switch	Fully Assembled to DDX Valve w/Control Valve	6505040208	6505060208	Not Available
	Fully Assembled to DDX Valve w/o Control Valve	6505040209	6505060209	6505065207
	Segmentally Assembled (DDX Valve Sold Separately)	6503001110		
	Individual Parts (DDX Valve Sold Separately)	6503001109		

### Electric Actuation Deluge (Explosion - Proof Solenoid Valve available upon request)

	Trim Configurations	Trim Part Numbers		
		For 4" (100 mm) Valve	For 6" (150 mm) Valve	For 165 mm Valve
175 psi (12,1 bar) Rated Solenoid Valve	Fully Assembled to DDX Valve w/ Control Valve	6505040210	6505060210	Not Available
	Fully Assembled to DDX Valve w/o Control Valve	6505040211	6505060211	6505065211
	Segmentally Assembled (DDX Valve Sold Separately)	6503001507	6503001003	
	Individual Parts (DDX Valve Sold Separately)	6503001505	6503001002	
250 psi (17,2 bar) Rated Solenoid Valve	Fully Assembled to DDX Valve w/ Control Valve	6505040215	6505060215	Not Available
	Fully Assembled to DDX Valve w/o Control Valve	6505040216	6505060216	6505065216
	Segmentally Assembled (DDX Valve Sold Separately)		6503001508	
	Individual Parts (DDX Valve Sold Separately)		6503001506	

**Note:** For metric installations, a 2" NPT x R2. ISO 7/1 x Close Nipple (Reliable P/N 98543401) is sold separately as an adapter for the single drain outlet of the trims.

- **Additional equipment** — Air compressors, electric detection, actuation equipment, and mechanical sprinkler alarms must be ordered separately. These devices are described in Bulletin 700.

# Installation Dimensions

Installation Dimensions in Inches (mm)																
VALVE	A	B	C	*D	E	F	G	H	J	K	L	M	N	P	Q	R
<b>4" (100mm)</b>	5¼ (133)	6¾ (171)	9½ (241)	14 (355)	29 (603)	22¾ (578)	30¾ (781)	8½ (216)	13¾ (349)	5½ (140)	8½ (216)	13½ (343)	2½ (64)	6¼ (159)	12 (305)	11¼ (286)
<b>6" (50mm) &amp; 165mm</b>	6¼ (159)	7¾ (197)	10½ (267)	16 (406)	30 (767)	23¾ (603)	31¾ (806)	8½ (216)	13¾ (349)	5½ (140)	8½ (216)	13½ (343)	3¼ (83)	8¾ (222)	12½ (318)	12¼ (311)

\* Total take out dimension for Fully Assembled to DDX Valve w/Control Valve Configurations:

4" - 20<sup>7</sup>/<sub>16</sub>, 6" - 23<sup>3</sup>/<sub>4</sub>, 165 mm - N/A

DRY PILOT LINE TRIM SHOWN (FULLY ASSEMBLED WITHOUT CONTROL VALVE)

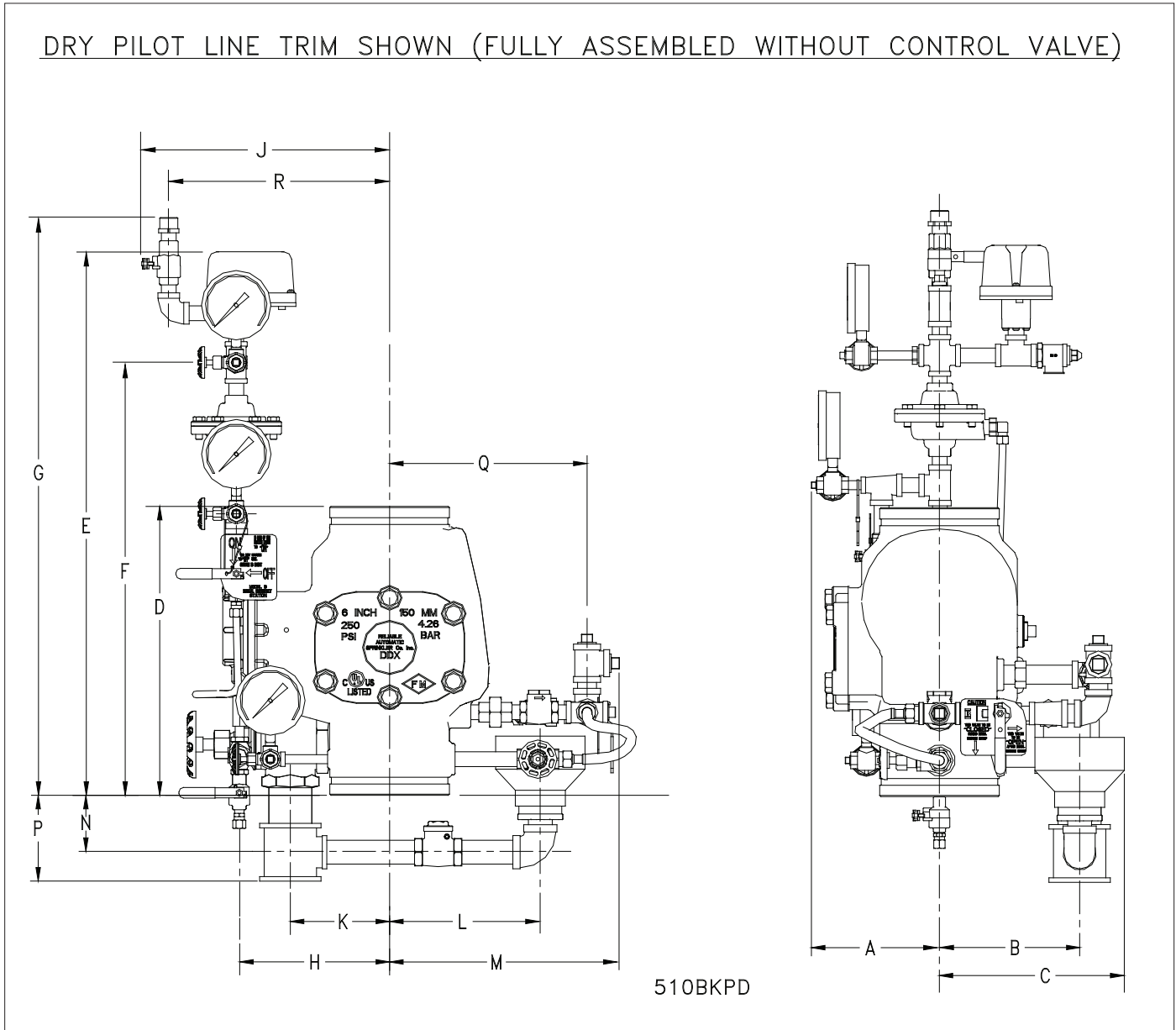

The equipment presented in this bulletin is to be installed in accordance with the latest published Standards of the National Fire Protection Association, Factory Mutual Research Corporation, or other similar organizations and also with the provisions of governmental codes or ordinances whenever applicable. Products manufactured and distributed by Reliable have been protecting life and property for over 90 years, and are installed and serviced by the most highly qualified and reputable sprinkler contractors located throughout the United States, Canada and foreign countries.

Manufactured by



The Reliable Automatic Sprinkler Co., Inc.  
 (800) 431-1588 Sales Offices  
 (800) 848-6051 Sales Fax  
 (914) 829-2042 Corporate Offices  
 www.reliablesprinkler.com Internet Address



Revision lines indicate updated or new data.  
 EG. Printed in U.S.A 12/10 P/N 9999970269