

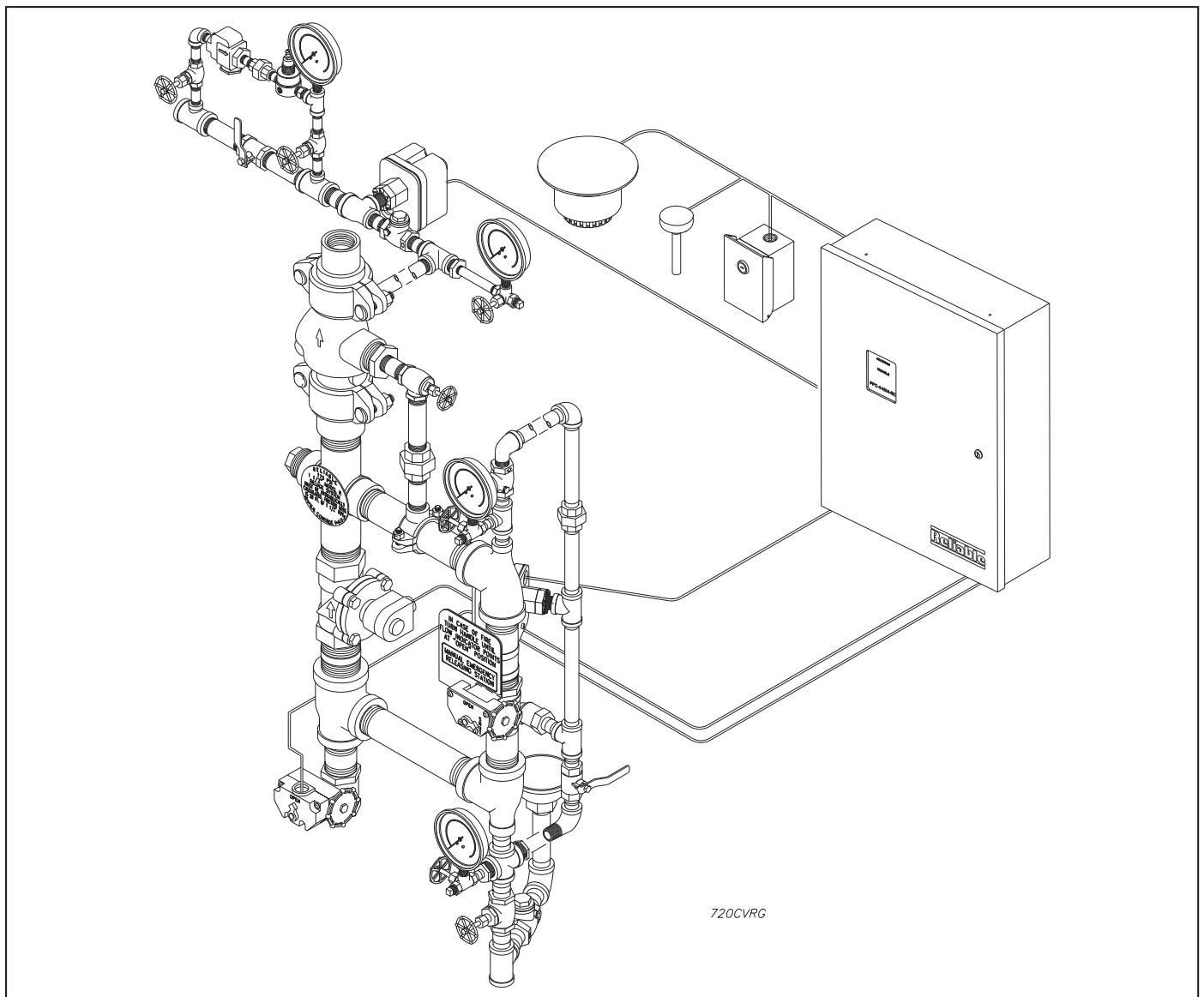

# Model H Double Interlock Preaction System 1½" (40mm)

## Instructions for Installation, Operation Care and Maintenance

10 PSI (0,7 bar) Pneumatic Supervising Pressure  
With Electric Pneumatic Actuation, Type D



## General Description

Reliable Preaction Systems are designed for water sensitive areas which require protection from inadvertent water flow into the sprinkler system piping.

The major benefits of a preaction system, when compared with a wet pipe system, are summarized as follows:

- A. A fire alarm sounds with activation of a detector and prior to the operation of a sprinkler, which may enable extinguishing the fire by handheld means before the operation of any sprinkler head occurs.
- B. An alarm condition occurs whenever the integrity of piping or sprinklers is accidentally or intentionally disturbed; however, no water flow or water damage will result at that time.
- C. Speedy detection with an early fire alarm is provided by fire detectors, without the delay associated with water delivery time in a wet pipe system in the event of a fire. Note that with a wet pipe system, the fire alarm is delayed until after water has begun flowing from an operated sprinkler head.

To flow water into an electric pneumatic double interlock preaction system, two events must take place. A fire detection device must operate, and a low pressure switch must be operated by the loss of system pressure (sprinkler operation). These two signals must coexist at the releasing control panel which only then will energize the solenoid releasing valve, causing water flow into the system and out of the open sprinkler(s).

This bulletin describes a Reliable Double Interlock Type D Preaction System which utilizes the Reliable Model H 1½" (40mm) Deluge Riser Assembly. This double interlock system uses fire detection devices and system supervisory pressure as two separate zones (inputs) to a cross-zoned Potter PFC-4410-RC Releasing/Control Panel. The system is pressurized (supervised) with air or nitrogen and monitored by the low pressure switch. The solenoid releasing valve remains closed until energized by the releasing control panel. This will occur only when both a fire detection device has operated and the low pressure switch has detected sufficient loss of system supervising pressure (sprinkler operation).

In the event that the system piping is ruptured or a sprinkler head is accidentally opened, the low pressure switch will operate and an alarm will sound. The riser assembly however, will not release water since the solenoid valve remains closed due to only one input into the cross-zoned control panel.

In the event that a fire detection device is falsely operated, the control panel will activate an alarm. The riser assembly, however, will not release water since the solenoid valve remains closed due to only one input into the cross-zoned control panel.

The requirement for simultaneous inputs from both a detector and the loss of supervising pressure before the riser assembly releases water into a preaction system assures maximum protection against inadvertent water flow before a sprinkler is open. Double interlock systems are primarily used to protect refrigerated areas where accidental water release before a sprinkler is opened can cause ice blockage, resulting in an inoperative sprinkler system and substantial property damage.

A hydraulic manual emergency releasing station is standard equipment in the Model H Riser Assembly. It is identified by a nameplate attached above the releasing valve.

A preaction trim kit is available to provide a bypass drain line and to attach the air or nitrogen supply required to supervise the preaction system. This kit includes a UL Listed Reliable Model G Right Check™ Valve supplied with rigid grooved pipe couplings, as illustrated in Figure 4. To produce a Double Interlock preaction system, the switch/gauge trim kit illustrated in Figure 5 must be added.

## Approvals

The 1½" Model H Riser Assembly is Underwriters Laboratories, Inc. Listed in the Special System Water Control Valves Deluge Type (VLFT) category. It is also listed by Underwriters' Laboratory of Canada. The Model G Right Check™ Valve is listed by UL and ULC. NYC MEA 258-93-E applies to both the Model H Riser Assembly and the Model G Right Check™ Valve.

## Technical Data

The 1½" (40mm) Reliable Double Interlock Preaction System is rated for a minimum supply pressure of 20 psi (1,4 bar) and a maximum supply pressure of 175 psi (12 bar).

Friction loss, expressed in equivalent length of Sch. 40 pipe and based on Hazen-Williams formula with C=120, and a flowing velocity of 15 ft./sec (4.6 m/s), is 29 ft (8.84m) for the Model H Riser Assembly, and 7 ft. (2.1m) for the 2½" (65mm) Model G Right Check™ Valve.

### Shipping Weights:

Model H Riser Assembly	52 lbs (23.6 kg)
Model A-2 Press. Maint. Dev.	9 lbs ( 4.0 kg)
Preaction Trim Kit	18 lbs ( 8.2 kg)
Pressure Switch/Gauge Kit	5 lbs ( 2.3 kg)
Model 1LAA-11T-M100X Tank Mounted Compressor	49 lbs (22.2 kg)

The following list of bulletins describe components which are used with this system:

Deluge Riser Assembly	507
Water Flow Pressure Alarm Switch (System Sensor)	A05-0176
Pressure Maintenance Device	251
Air Compressor (Tank Mounted)	700
Releasing/Control Panel	Potter #5403550
Electric Emergency Station	700
Thermal Detectors	722
Fire Alarm Devices	700
Automatic Nitrogen Reg. Device	253
Model G Right Check™ Valve	806

### System Design Considerations

The automatic sprinklers, air compressor, releasing devices, electric releasing control panel, fire detection devices, manual pull stations, and signaling devices which are utilized with the Systems must be UL and/or ULC Listed, as applicable.

The Reliable Double Interlock Preaction Riser equipment (Figure 6) and all interconnecting piping must be located in a readily visible and accessible location and in an area which can be maintained at a minimum temperature of 40°F (4°C).

**NOTE:** HEAT TRACING IS NOT PERMITTED.

The solenoid valve is operated and supervised by the electric releasing control panel. Details on connecting the electrical portion of this system to a Releasing/Control Panel can be found in Reliable Bulletin 700.

### Hydrostatic Testing of Systems

As required by NFPA 13, fire sprinkler systems with working pressures up to and including 150 psi are to be hydrostatically tested at a water pressure of 200 psi and maintain that pressure without loss for two hours. Fire sprinkler systems with working pressures above 150 psi are required to be hydrostatically tested at 50 psi above the system working pressure and maintain that pressure without loss for two hours. In addition to the hydrostatic tests described above, dry pipe and double interlock preaction systems require an additional low pressure air test.

In some cases, hydrostatic testing (in accordance with the NFPA 13 requirements noted above) will result in pressures that exceed the working pressure of the valve and trim kit for the two-hour test period. The valve and applicable trim kit have been tested, approved and listed under these conditions and as such, hydrostatic testing in accordance with NFPA 13 is acceptable. In addition, the clapper can remain in the closed position and the trim kit need not be isolated, as each has been designed to withstand hydrostatic testing as required by NFPA 13.

Hydrostatically testing the valve and trim to pressures higher than their rating is limited to the hydrostatic test as referenced by NFPA 13. It does not address the occurrence(s) of a “water hammer” effect, which can indeed damage the valve. A “water hammer” in the water supply piping of the valve can create pressures in excess of the rated pressure and should be avoided by all necessary means. This condition may be created from improper fire pump settings, underground construction work, or an improper venting of trapped air in the water supply piping.

### System Air Pressure Requirements

In accordance with NFPA 13 (1996), the Reliable Double Interlock Type D Preaction System requires a minimum of 7 psi (0,5 bar) pneumatic pressure to supervise the sprinkler system. The Model A-2 Pressure Maintenance Device is used to maintain system pneumatic pressure at approximately 10 psi (0,7 bar). The Model A-2 Pressure Maintenance Device controls supervisory pressure where a dry nitrogen gas supply or a clean, dependable and continuous (24 hours per day, 7 days per week) compressed air source is available.

Adjusting system pressure to approximately 10 psi (0,7 bar) is accomplished by referring to Reliable Bulletin 251 for adjustment procedure. The low pneumatic pressure supervisory switch (Item 5, Figure 5) is factory set to operate between 8 and 4 psi (0,55 and 0,28 bar) with decreasing pressure. Adjustment, if required, should be made according to Bulletin A05-0176 included with the switch.

### System Electrical Requirements

All releasing, alarm and detection devices in the Reliable Double Interlock Preaction System are supervised by the Potter PFC-4410-RC Releasing/Control Panel. Typical connections of these devices are shown in Figure 1.

Connect the Common (C) and Normally Closed (NC) terminals of the system low pressure switch (Figure 5) to initiating Zone 2 as shown in Figure 2 or 3. Switch contacts must be in the open position when the system is pneumatically pressurized to 10 psi (0,5 bar). Install fire detection devices to initiating Zone 1 as shown in Figure 2 or 3.

The power supply, standby emergency power supply, battery charger and rectifier circuitry are all contained within the Potter PFC-4410-RC Releasing/Control Panel. Batteries that provide up to 90 hours of standby power are stored inside the panel.

For additional information and details on wiring refer to Reliable Bulletin 700. Selection of Class A or B wiring must be according to local codes and the Authority Having Jurisdiction.

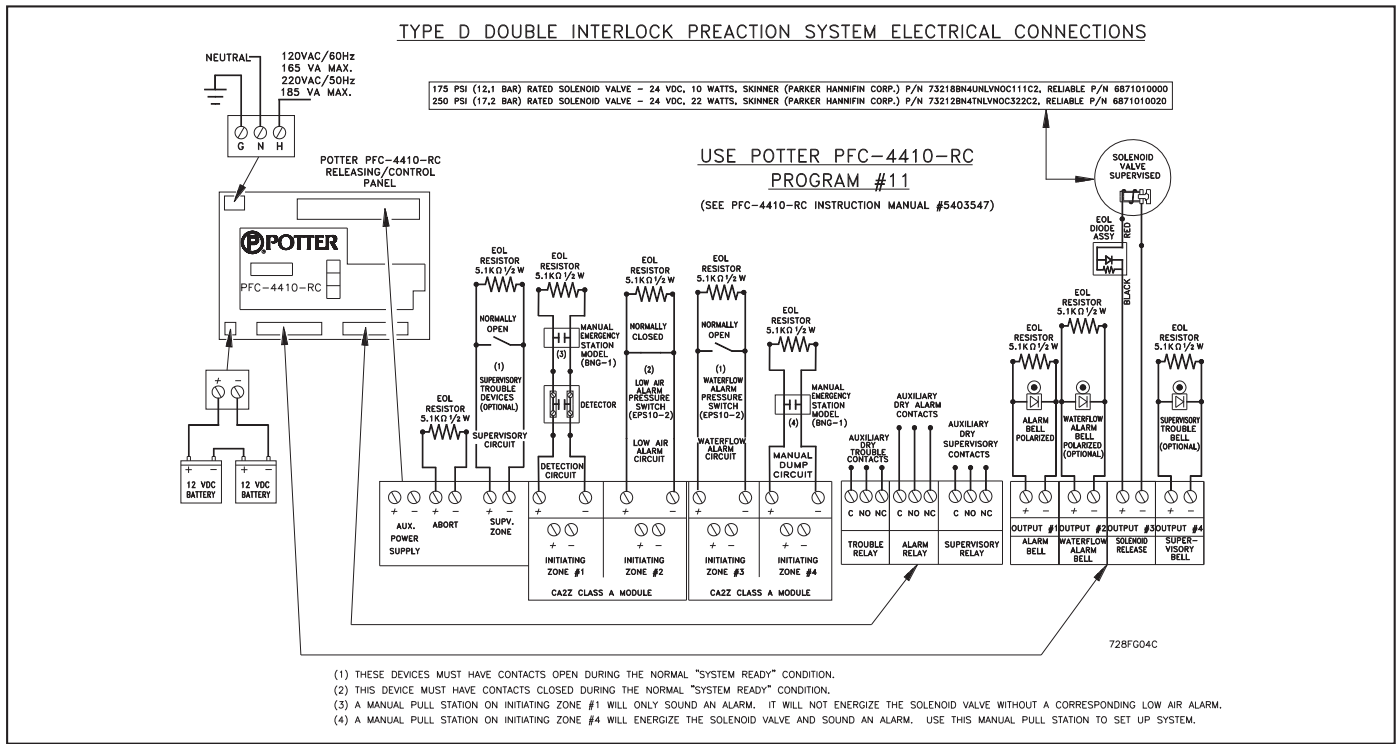

Figure 1

## System Operation

The Reliable Double Interlock Type D Preaction System requires two independent events to coexist before water flow will occur. A fire detection device must operate and the low pneumatic pressure switch must actuate by reducing the system supervising pressure (sprinkler operation). The cross-zoned control panel will now energize the solenoid valve to release water through the riser assembly into the system piping and out the open sprinkler for complete operation of the system.

The Reliable Double Interlock Preaction System will automatically operate only when both a fire detection device and the low supervising pressure switch are activated. Operation of either one of these items will only cause an alarm to annunciate, and will not fill the sprinkler system piping with water.

When the releasing control panel energizes the solenoid valve open, water flows from the supply through the riser assembly into the system and to the water flow alarm pressure switch. The valve maintains its open position until the solenoid is de-energized.

**Caution:** The solenoid valve must be maintained open to prevent automatic closing of the Model H Deluge Riser Assembly. The Potter PFC-4410-RC Releasing/Control Panel has a latching feature for this purpose.

After system shutdown and draining, the riser assembly is easily reset without special tools. First, restore all sprinklers exposed to excessive heat and then restore detection devices by resetting or replacing any operated device. Once detection devices are restored, reset the low supervisory pressure switch by restoring

the supervisory pressure to 10 psi (0,5 bar). Subsequently reset the releasing control panel (see Bulletin 700) and the supply pressure (see Bulletin 507).

## Double Interlock Riser Installation

The recommended sequence of installation is as follows (refer to Figure 6):

1. Install the Pre-assembled Deluge Riser Assembly (P/N 6503003001) in accordance with Bulletin 507, "Model H Deluge Riser Assembly."
2. The Preaction Trim Kit (P/N 6501200112), illustrated in Figure 4, consists of items 1 through 17. The assembly has a convenient arrangement for draining the sprinkler system through the Model H Riser Assembly drain line.

Assemble the preaction trim kit, as illustrated, using a suitable Teflon-based pipe thread sealant applied to each male thread.

Assemble rigid couplings by first applying a thin coat of silicone or other lubricant that does not contain hydrocarbons to the lips and outside surfaces of the gasket. Position gaskets uniformly on the valve and adjacent reducers so that all grooves are exposed. Place coupling housings over gaskets and engage the housing keys in the grooves. Insert bolts and tighten nuts alternately until housing halves are drawn together uniformly.

3. The Double Interlock Switch/Gauge Trim Kit (P/N 6501200110 or P/N 6501200119), illustrated in Figure 5, consists of items 1 through 6. Assemble the kit using a suitable Teflon-based pipe thread sealant applied to each male thread.

Verify that the check valve orientation is according to the directional flow arrow illustrated.

Install the pressure gauge included with this trim kit into the Model A-2 Pressure Maintenance Device after removing the 1/4" NPT (R1/4) plug, as illustrated in Figure 6.

The pressure switch is factory adjusted for operation between 8 to 4 psi (0,55 to 0,28 bar). If field adjustment is required or the lowest possible setting (4 psi or 0,28 bar) is desired, refer to Figure 5 and proceed as follows:

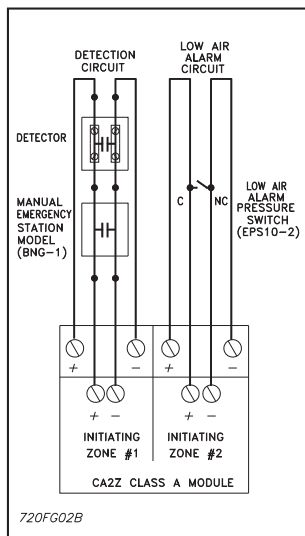

**Class A Wiring**  
Figure 2

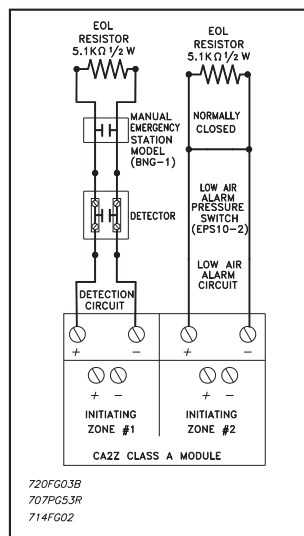

**Class B Wiring**

- Remove cover using wrench provided.
- Loosen locking screw until adjustment wheel rotates freely.
- Rotate adjustment wheel clockwise to end of adjustment for lowest setting possible.
- Re-tighten locking screw to initial conditions.
- Replace cover.

Switch contact ratings are:

10A, 1/2 HP @ 125/250 VAC  
2.5A, @ 6/12/24 VDC

**Consult the enclosed switch manufacturer's literature (Bulletin A05-0176) for more detailed information.**

4. Install the Pre-assembled Model A-2 Pressure Maintenance Device (P/N 6304000100) with pressure gauge in place, onto the Switch/Gauge Trim Kit as illustrated in Figure 6. Adjust the output pressure to approximately 10 psi (0,7 bar) according to the instructions in Bulletin 251, included.
5. When a dedicated pneumatic pressure supply is required, a small tank mounted air compressor [such as the 1/8 hp, 2 gal. (7.6 liters) Gast Model 1LAA-11T-M100X illustrated in Figure 6] can be used to input the Model A-2 Device.

If moisture and possible ice blockage is of concern, a dry nitrogen gas cylinder with the Nitrogen Regulating Device described in Bulletin 253, and illustrated in Figure 6, can be used to supply the Model A-2 Device.

## Maintenance

Reliable Double Interlock Preaction Systems and associated equipment shall periodically be given a thorough inspection and test. NFPA 25, Inspection, Testing and Maintenance of Water Based Fire Protection Systems, provides minimum maintenance requirements. Systems should be tested, operated, cleaned and inspected at least annually, and parts replaced as required. Refer to Bulletin 507 for information regarding maintenance of the solenoid valve and the manual emergency station valve. Bulletin 251 provides information on the Model A-2 Pressure Maintenance Device. Bulletin 253 describes the automatic Nitrogen Regulating Device.

## Resetting Double Interlock Systems

Refer to Figure 6.

1. Close the supervised valve controlling water supply to the riser assembly and shut off the system air/nitrogen supply at the Model A-2 Pressure Maintenance Device.
2. Open all drain valves and the manual emergency station valve to drain the system.
3. Open all drain valves and vents at low points throughout the system, closing them when flow of water to drain has stopped.
4. Inspect and replace any portion of the sprinkler system and detection system exposed to fire conditions. Reset detectors (refer to Bulletin 700).  
**Note:** It is not possible to reset the Potter PFC-4410-RC Releasing/Control Panel (which is in the cross-zoned mode) until Step "6", which resets the low supervising pressure switch, has been completed.
5. Restore the system supervising pressure to approximately 10 psi (0,7 bar) by opening the valves on the Model A-2 Pressure Maintenance Device (refer to Bulletin 251) and adjusting the regulator, as required.
6. Verify that the by-pass drain valve is closed to prevent the loss of pneumatic supervising pressure out of the automatic drain valve. When the supervising pressure has reached the 10 psi (0,7 bar) setting, the low supervising pressure switch will automatically reset (contacts now open).
7. With the supervising pressure switch reset (Step "6") and all detectors replaced or reset (Step "4"), the Potter PFC-4410-RC Releasing/Control Panel can be reset. Pushing the "System Reset" switch in the panel will simultaneously restore the solenoid valve to the closed condition.
8. Restore water supply to the riser assembly in accordance with Bulletin 507, "Model H Deluge Riser Assembly Instructions for Installation, Operation, Care and Maintenance."

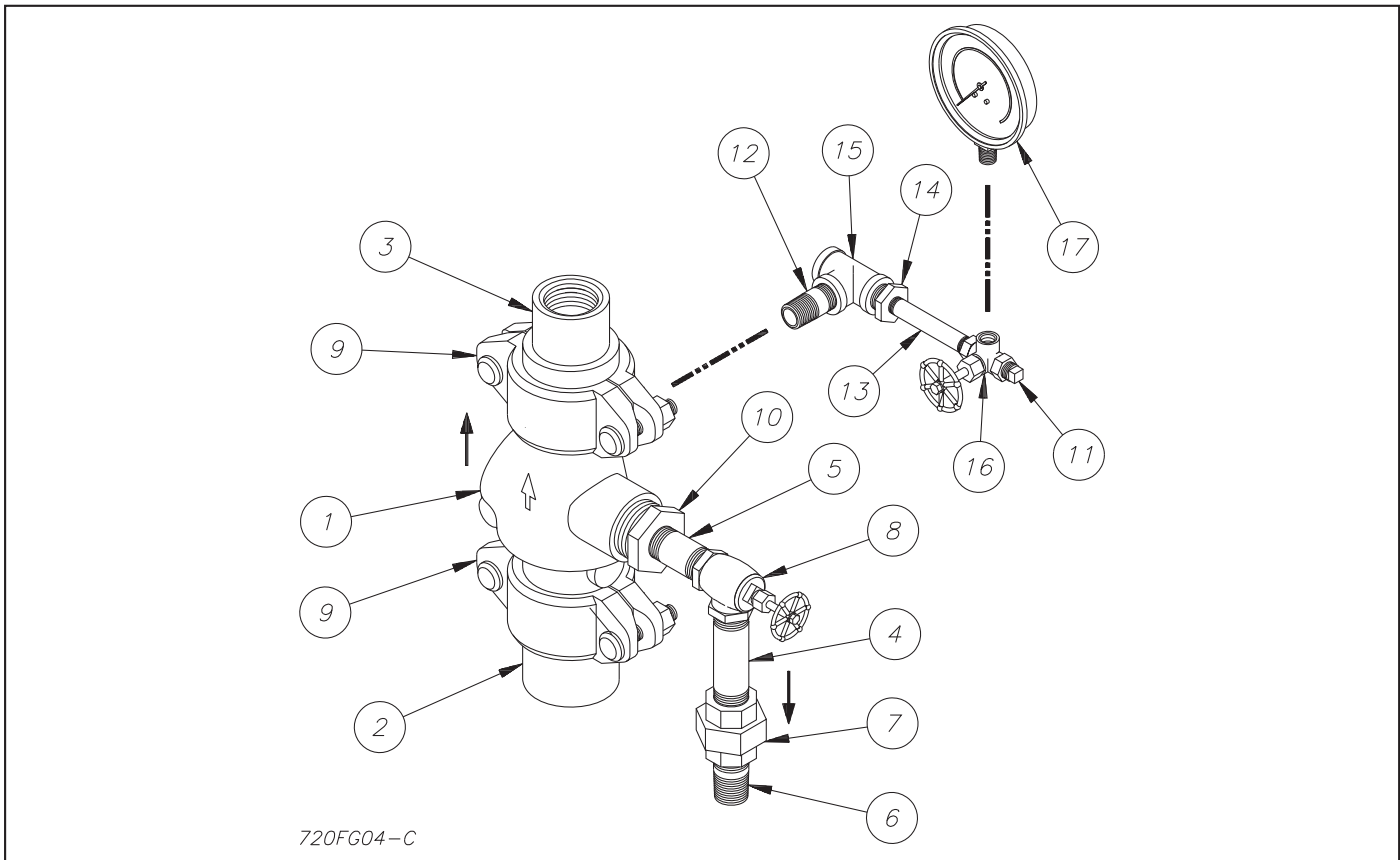

Figure 4 — Preaction Trim Kit

**Parts List, P/N 6501200112**

Item No.	Part No.	Description	No. Req'd.
1	6107020000	Valve, Check, 2½" Model G	1
2	98050002	Reducer, 2½" GRV. x 2" NPTF	1
3	98050003	Reducer, 2½" GRV. x 1½" NPTF	1
4	98543234	Nipple, ¾" x 3½" Lg. (Galv.)	1
5	98543231	Nipple ¾" x 3" Lg. (Galv.)	1
6	98543279	Nipple, ¾" x Close (Galv.)	1
7	98815202	Union, ¾" (Galv.)	1
8	98840113	Valve, Angle ¾" NPT	1
9	7S05101000	Coupling Rigid, 2½"	2
10	98048035	Bushing, 1¼" x ¾" (Galv.)	1
11	96614403	Plug, ¼" (Galv.)	1
12	98543212	Nipple, ½" x Close (Galv.)	1
13	96543220	Nipple, ¼" x 3" Lg. (Galv.)	1
14	98048000	Bushing, ½" x ¼" (Galv.)	1
15	98761651	Tee, ½" (Galv.)	1
16	98840160	Valve, 3-way gauge, ¼"	1
17	98248000	Gauge, Air Pressure	1

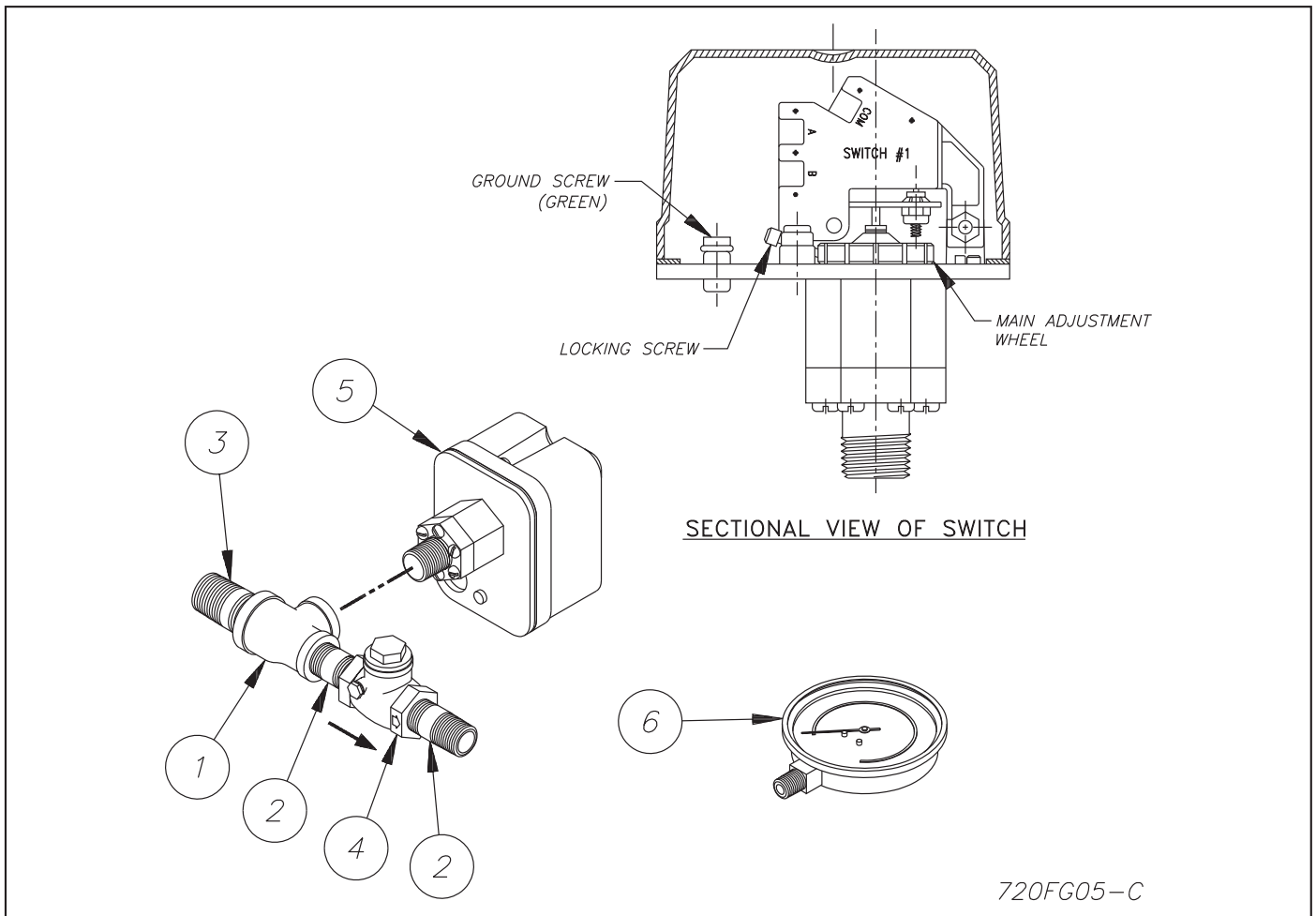

Figure 5 — Double Interlock  
Switch/Gauge Trim Kit

**Parts List, P/N 6501200110  
P/N 6501200119 (Canadian)**

Item No.	Part No.	Description	No. Req'd
1	96606612	Tee, 3/4" x 1/2" x 1/2" (Galv.)	1
2	98543212	Nipple, 1/2" x Close (Galv.)	2
3	98543279	Nipple, 3/4" x Close (Galv.)	1
4	98840181	Valve, Check, Horizontal, 1/2"	1
5	6999991339	Switch, Pressure (EPS10-1)	1
	6999992366	Switch, Pressure (EPS10-1) (Canadian)	
6	98248000	Gauge, Pressure, Air	1

**Inspection and Testing**

Refer to Figure 6.

- Water supply** - be sure the valve controlling water supply to the riser assembly is open fully and properly supervised.
- Other trimming valves** - check that all pressure gauge valves are open, and that the Model A-2 Pressure Maintenance Device 3/4" NPT (R3/4) fill valve is

closed. The two 1/4" NPT (R1/4) by-pass line valves must be fully open.

- Check that system supervising pressure is approximately 10 psi (0,7 bar).
- Operation test - for detection only, operate by actuation of a keyed manual (electrical) emergency station (refer to Bulletin 700, "Special Hazards & Special Systems," for details). Double interlock systems also require the supervisory pressure to be discharged, through the inspectors test station, or other venting means, below 4 psi (0,28 bar) before total system operation will occur.

**Note:** Total system operation testing will cause water flow through the riser assembly and into the system. Where difficulty in performance is experienced, contact Reliable Technical Services before any field adjustment is to be made.

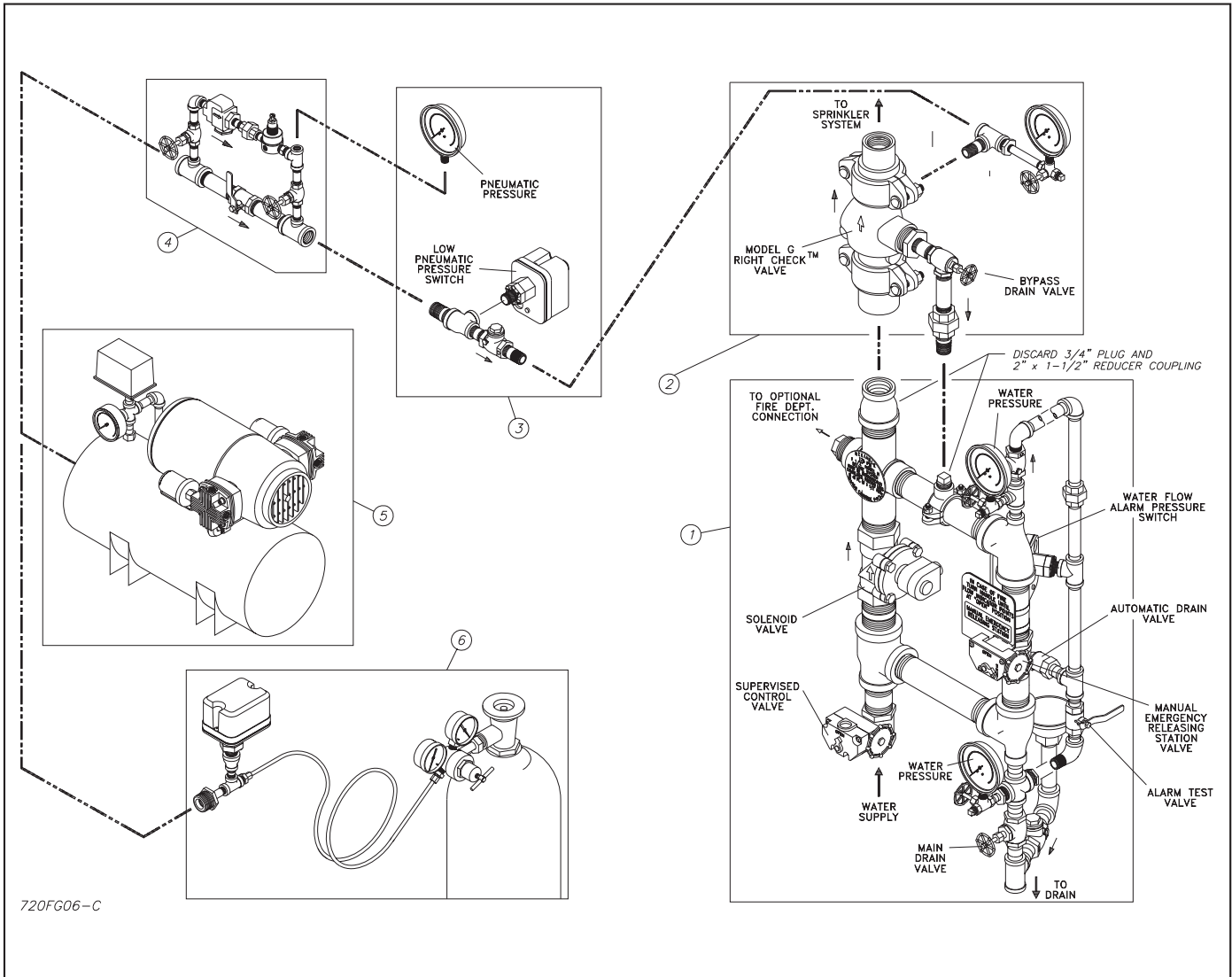
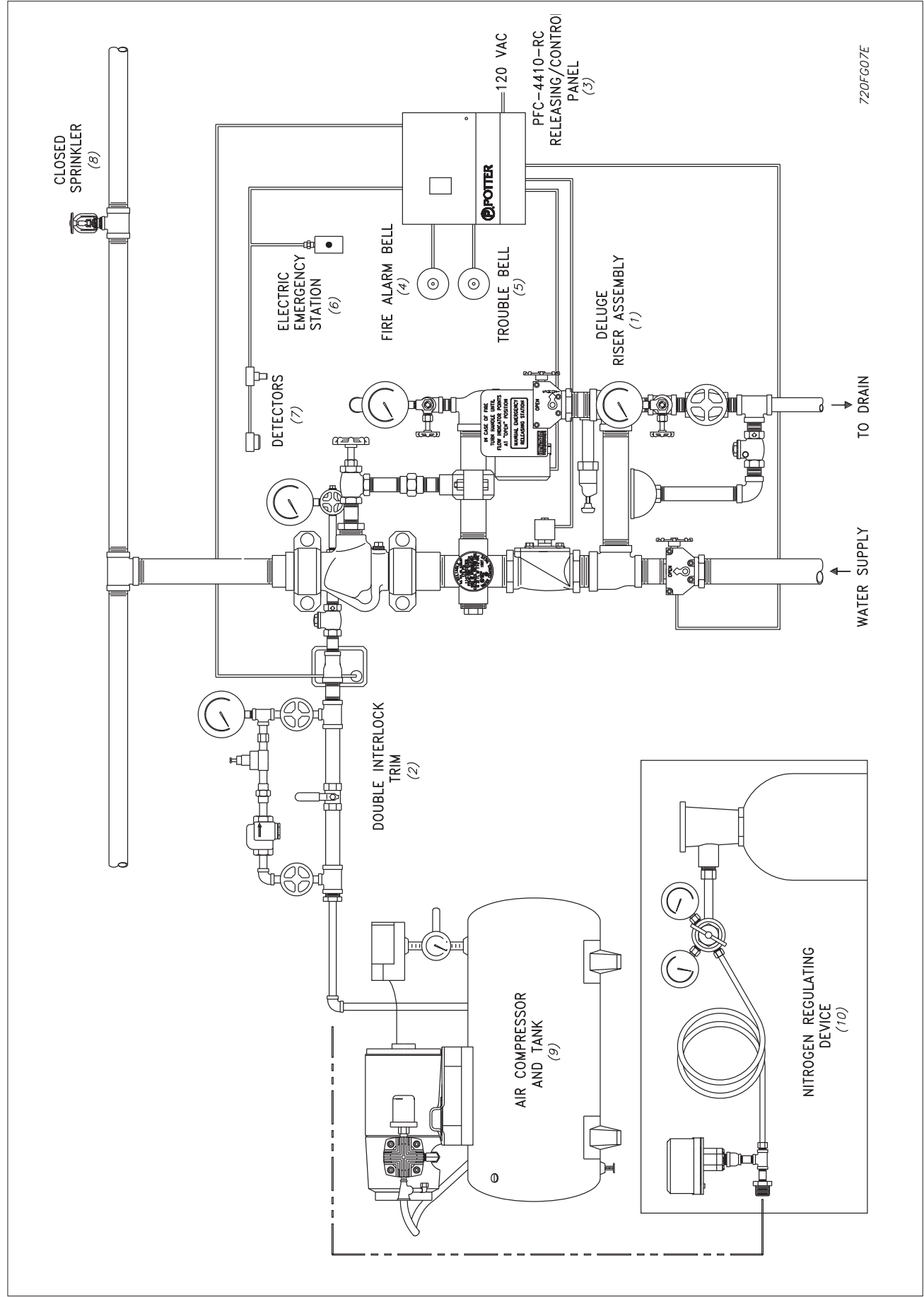

Figure 6 — Double Interlock Preaction, Component Identification

Item No.	Part No.	Description	No. Required
1	6503003001	Model H Deluge Riser Assembly	1
	6503003007	Model H Deluge Riser Assembly (Canadian)	
2 <sup>(1)</sup>	6501200112	Preaction Trim Kit	1
3 <sup>(1)</sup>	6501200110	Double Interlock Switch/Gauge Trim Kit	1
	6501200119	Double Interlock Switch/Gauge Trim Kit (Canadian)	
4 <sup>(1)</sup>	6304000100	Model A-2 Pressure Maintenance Device	1
5	6999991027	Model 1 LAA-11T-M100X Tank Mounted Compressor	Optional
6	6304030101	Nitrogen Regulation Device (Tank Not Included)	Optional
	6304030107	Nitrogen Regulation Device (Tank Not Included) (Canadian)	

<sup>(1)</sup>These 3 items are combined under Part Number 6503003405 or Part Number 6503003407 for Canadian Version, as the 1½" Double Interlock Trim. (Item 2, Page 10)





720FG07E

Figure 7 - Double Interlock Preaction System

## Total System Operation Testing Without Causing Water Flow

Refer to Figure 6.

1. Close the supervised valve controlling water supply to the riser assembly, and note the lower water pressure gauge reading.
2. Operate a double interlock system by operating one detector and also venting the supervising pressure through the inspectors test station, below 4 psi (0,28 bar), to operate the low pressure switch.
3. Operation of a detector and the low supervising pressure switch must result in a sudden drop of water pressure as the solenoid valve opens. When the water pressure gauge drops to zero, open the main drain and by-pass drain valves until all water above the supervised control valve drains away.
4. Reset system by following the operation described previously in Steps 5 through 7. All detection devices must be reset before the Potter PFC-4410-RC Releasing/Control Panel can be reset.
5. Open slightly the supervised valve controlling water supply to the riser assembly, closing the main drain valve after water flows steadily through it. Open slowly but fully the control valve and supervise it properly. Verify there is adequate water supply pressure and proper pneumatic supervisory pressure on the appropriate gauges. There should be no pressure reading on the water gauge directly above the manual emergency releasing station when the system is properly reset.

## Ordering Information

Specify:

Item No.	Component Part	Mfr.	Description	Technical Bulletin
1	Deluge Riser Assembly	B	Model H	507
2	Double Interlock Trim	B	Refer to Parts List in this Bulletin	720
3	Releasing / Control Panel	C	Model PFC-4410-RC	Potter #5403550 Reliable 700
	Batteries		12 VDC, 12 AMP Hours (90 Hours Backup) FM 12 VDC, 7 AMP Hours (60 Hours Backup)	
	Optional Accessories		CA2Z (Class A Wiring Module for Initiating Circuits)	
			CAM (Class A Wiring Module for Indicating Circuits)	
			ARM-1 / ARM-2 (Auxiliary Relay Module)	
	RA-4410-RC (Remote Annunciator)			
4	Alarm Annunciator	A	Model SSM24-8 24 VDC / Polarized Bell	Reliable 700
			Model SSM24-10 24 VDC / Polarized Bell	
			Model MA24-D 24 VDC / Polarized Sounder	
			Model MASS24LO 24 VDC / Polarized Sounder Strobe	
5	Trouble Annunciator	A	Model SSM24-6 24 VDC / Polarized Bell	Reliable 700
			Model MA24-D 24 VDC / Polarized Sounder	
6	Manual Emergency Station (Elec.)	A	Model BNG-1 (SPDT) 1 & 2 Area Detection	Reliable 700
			Model BNG-1F (DPDT) Cross Zoned Detection	
7	Detection	Various	Smoke, Heat Detectors, etc.	Reliable 722
8	Sprinklers	B	Closed Type	Reliable 110, 117, 131, 136, etc.
9	Air Compressor with Tank	D	Model 1LAA-11T-M100X, 1/6 Hp w/ 2 Gallon Tank	F30
10	Nitrogen Regulating Device	B	Regulator with Optional Low Air Pressure Switch	Reliable 253

## System Equipment Manufacturers

- (A) Notifier  
 (B) The Reliable Automatic Sprinkler Co., Inc.  
 (C) Potter Electric Signal Company.  
 (D) Gast Manufacturing Corp.

## Patents

**US Patent No. 5,720,351**

Installation Dimensions in Inches

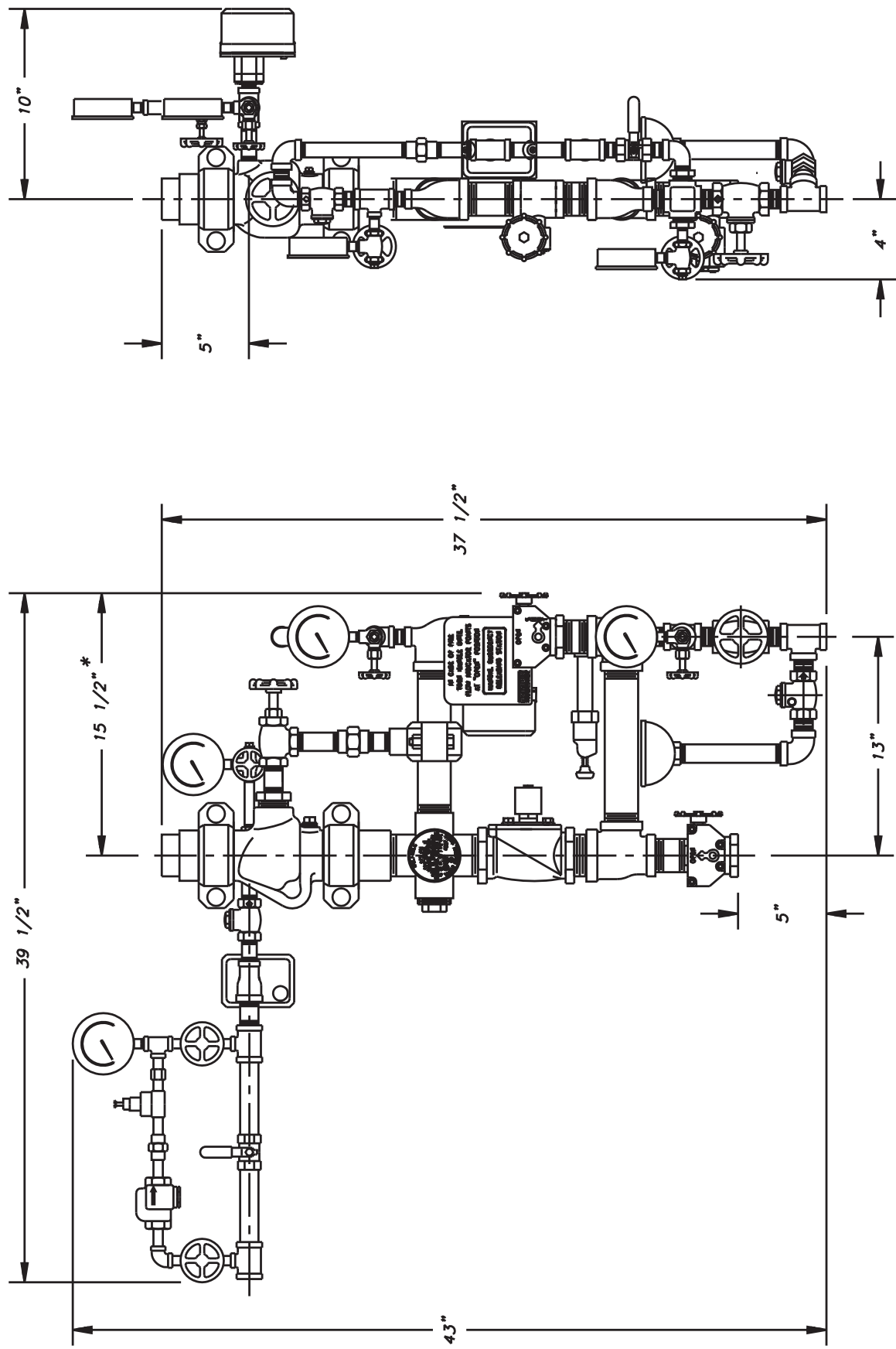

720DIM-G  
707PG112B

## **SOLENOID VALVE INSPECTIONS, TESTS AND MAINTENANCE**

**WARNING: THE OWNER IS RESPONSIBLE FOR MAINTAINING THE FIRE PROTECTION SYSTEM IN PROPER OPERATING CONDITION. ANY SYSTEM MAINTENANCE OR TESTING THAT INVOLVES PLACING A CONTROL VALVE OR DETECTION SYSTEM OUT OF SERVICE MAY ELIMINATE THE FIRE PROTECTION OF THAT SYSTEM. PRIOR TO PROCEEDING, NOTIFY ALL AUTHORITIES HAVING JURISDICTION. CONSIDERATION SHOULD BE GIVEN TO EMPLOYMENT OF A FIRE PATROL IN THE AFFECTED AREA.**

**WARNING: PRIOR TO OPERATING THE SOLENOID VALVE, BE SURE TO CLOSE THE SYSTEM CONTROL VALVE TO AVOID UNINTENTIONAL OPERATION OF THE DELUGE VALVE**

1. Inspections: It is imperative that the system be inspected and tested in accordance with NFPA 25 on a regular basis. The frequency of the inspections may vary due to contaminated water supplies, corrosive water supplies, or corrosive atmospheres. In addition, the alarm devices, detection systems, or other connected trim may require a more frequent schedule. Refer to the system description and applicable codes for minimum requirements.
2. The valve must be operated at least monthly. The valve must open and close freely. When open, the water flow must be clear and clean at the proper flow rate. When closed, a total water shut-off must be observed.
3. The valve must be inspected at least monthly for cracks, corrosion, leakage, etc., and cleaned, repaired, or replaced, or replaced as necessary.
4. At least annually, the valve diaphragms and seats must be inspected and if necessary, repaired or replaced.

**WARNING: CLOSE SYSTEM CONTROL VALVE, TURN OFF POWER SUPPLY, AND DEPRESSURIZE VALVE BEFORE DISASSEMBLING VALVE. IT IS NOT NECESSARY TO REMOVE THE VALVE FROM THE PIPE LINE TO MAKE INSPECTIONS.**

5. When lubricating valve components, use high grade silicone grease (Dow Corning® 111 Compound Lubricant or equal).
6. When reassembling, tighten parts to torque values indicated in the manufacturer's maintenance instructions (packed with valve).
7. After maintenance is completed, operate the valve a few times to be sure of proper operation. A metallic "click" signifies the solenoid is operating.
8. It is recommended that the valve be replaced at seven-year intervals. Shorter intervals may be required if the valve is subject to corrosive water supplies or atmospheres.
9. All service must be performed by qualified personnel. Upon completion of inspections or replacement of the valve, the entire system must be checked for proper operation. See appropriate system description and testing instructions for additional information.

---

The equipment presented in this bulletin is to be installed in accordance with the latest pertinent Standards of the National Fire Protection Association, Factory Mutual Research Corporation, or other similar organizations and also with the provisions of governmental codes or ordinances whenever applicable.

Products manufactured and distributed by Reliable have been protecting life and property for over 80 years, and are installed and serviced by the most highly qualified and reputable sprinkler contractors located throughout the United States, Canada and foreign countries.

---

Manufactured by

**Reliable®**

**The Reliable Automatic Sprinkler Co., Inc.**

(800) 431-1588  
(800) 848-6051  
(914) 829-2042  
[www.reliablesprinkler.com](http://www.reliablesprinkler.com)

Sales Offices  
Sales Fax  
Corporate Offices  
Internet Address



Recycled  
Paper

Revision lines indicate updated or new data  
E.G. Printed in USA. 05/08 P/N9999970124