

Reliable®

Double Interlock Preaction System Type D 8" (200 mm) Size

Instructions for Installation, Operation, Care and Maintenance

- Available with 175 psi (12,1 bar) or 250 psi (17,2 bar) Pneumatic Supervising Pressure
- Externally Resettable Clapper
- One Main Drain

7 to 10 PSI (0,5 to 0,7 bar) Pneumatic Supervising
Pressure With Electric / Pneumatic Actuation
Controlled by a Cross-Zoned Releasing Control Panel
Type D System

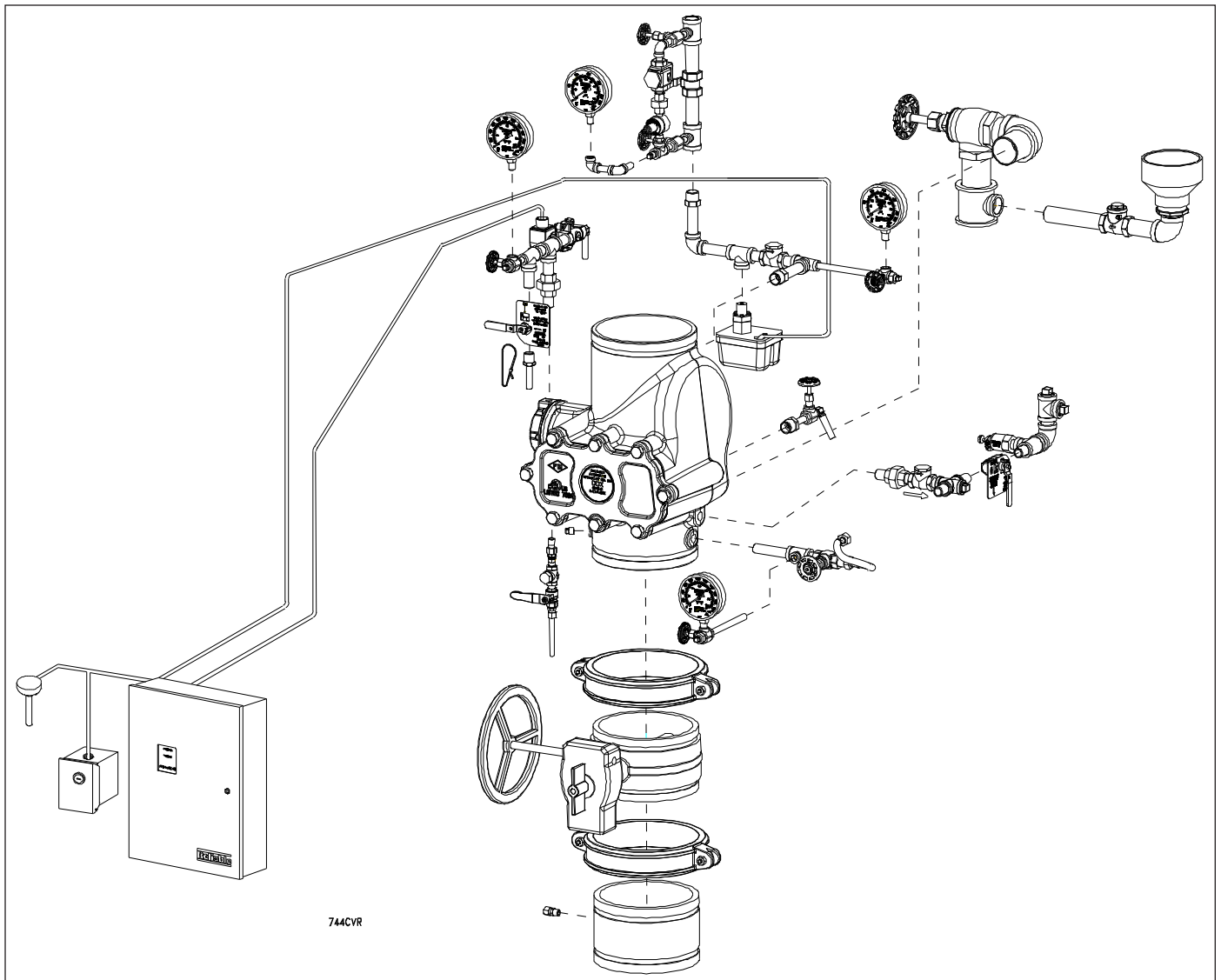

General Description

Double Interlock Praction Systems are designed for water-sensitive areas that require the maximum protection from inadvertent water flow into the sprinkler system piping. A refrigerated area is an example of this type of water sensitive environment.

To flow water into a Type D Double Interlock Praction System, two events must take place. A fire detection device must operate, and the low air pressure switch must be operated by the loss of system air pressure (sprinkler operation). These two signals must coexist at the releasing control panel, which only then will energize the normally closed solenoid valve (175 psi (12,1 bar) or 250 psi (17,2 bar) rated), causing water flow into the system.

These Systems utilize fire detection devices and system air pressure as separate zones (inputs) to a cross-zoned releasing control panel. The solenoid releasing valve remains closed until energized by the releasing control panel. This will occur only when both a fire detection device is operated and the low air pressure switch has detected sufficient loss of system air pressure (sprinkler operation).

In the event that the system piping is ruptured, or a sprinkler head is accidentally opened, the low air pressure switch will operate and an alarm will sound. The Model DDX Deluge Valve, however, will not be released to flow water since the solenoid valve remains closed due to the cross-zoned control panel configuration. The same end result would occur if a fire detection device were falsely operated. The control panel will activate an alarm, however again, the Model DDX Deluge Valve will not flow water due to the cross-zoned control panel configuration.

This requirement for both a detector to operate and the loss of system air pressure before the Model DDX Deluge Valve releases water into a preaction system assures maximum protection against inadvertent water flow before a sprinkler is open. Double interlock preaction systems are primarily used to protect refrigerated areas where accidental water release

before a sprinkler is opened can cause ice blockage, resulting in an inoperative sprinkler system and substantial property damage.

At the heart of Reliable's Type D Double Interlock Praction System is the Model DDX Deluge Valve. This Deluge Valve is a hydraulically operated, straight-through-design, differential latching clapper-type valve (see Fig. 1). System maintenance is simplified since priming water is not required and the Deluge Valve can be reset externally without cover removal. This is accomplished by pushing in and turning the external reset knob at the rear of the Deluge Valve (see Fig. 1). This feature provides a significant system-restoration time advantage.

The Reliable Type D Double Interlock Praction System trim set (see Fig. 2) provides all of the necessary equipment for connections to the Model DDX Deluge Valve's pushrod chamber inlet and outlet ports, the 2" (50mm) main drain, alarm devices, air supply, water supply, and required pressure gauges. This trim set is available in individual parts, in time-saving, segmentally assembled kit forms, or fully assembled to the Model DDX Deluge Valve (with or without a control valve).

Listings & Approvals

Reliable Type D 8" (200mm) Double Interlock Praction Systems are Factory Mutual Approved Refrigerated Area Sprinkler Systems for use in refrigerated rooms or buildings. Refrigerated area sprinkler systems are FM Approved as complete systems. Systems are FM approved for use with thermal detectors and Class A detector wiring only.

Reliable Type D 8" (200mm) Double Interlock Praction Systems are Listed by Underwriters Laboratories, Inc. and UL certified for Canada (cULus) as Special System Water Control Valves – Double Interlock Type (VLJH) category.

The Reliable Type D Double Interlock Praction System is UL Listed and FM Approved only when used with the trim components shown in Fig. 2.

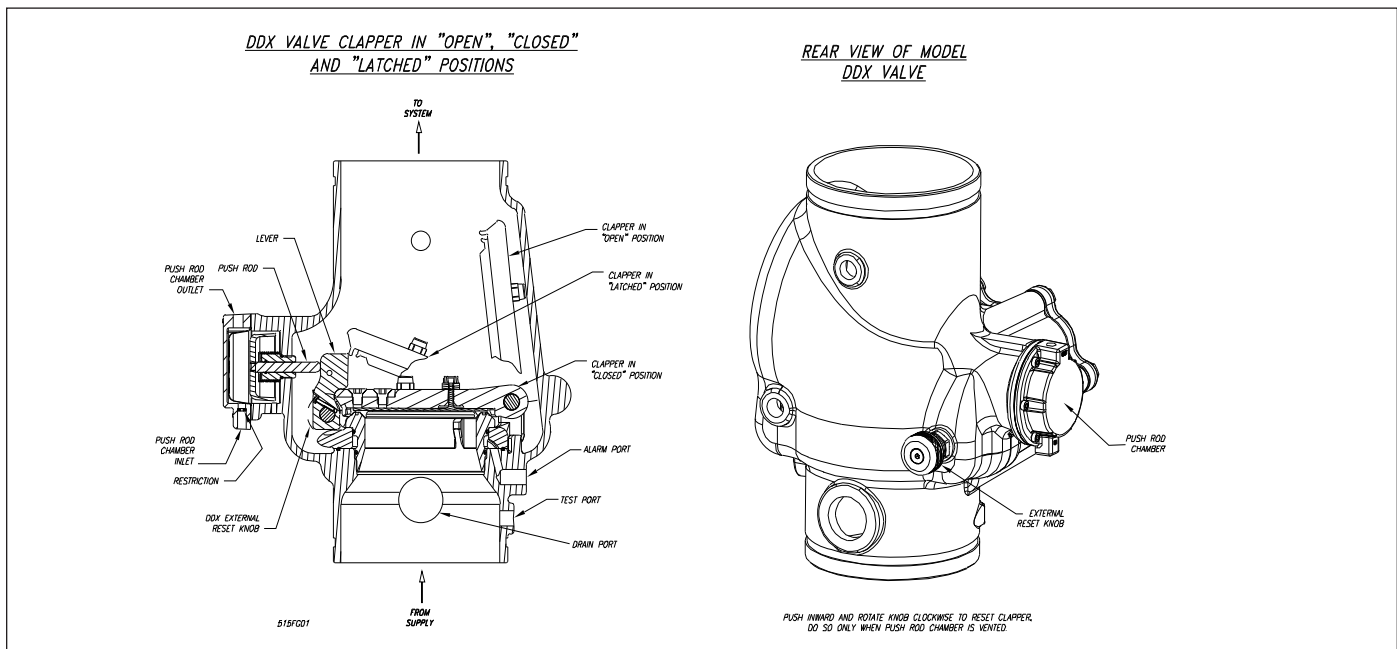

Fig. 1

System Operation

When set correctly for service, the Model DDX Deluge Valve is hydraulically established to withhold the supply water from the sprinkler system piping. The Reliable Model DDX Deluge Valve is shown in both closed and open positions in Fig. 1. In the closed position, the supply pressure acts on the underside of the clapper and also on the pushrod through the push rod chamber's inlet restriction. The resultant force due to the supply pressure acting on the push rod is multiplied by the mechanical advantage of the lever and is more than sufficient to hold the clapper closed against normal supply pressure surges.

Whenever a fire and a low system air pressure condition are detected, the energized solenoid valve vents the push rod chamber to atmosphere through the chamber's outlet. Since the pressure cannot be replenished through the inlet restriction as rapidly as it is vented, the push rod chamber pressure falls instantaneously. When the pushrod chamber pressure approaches approximately one-third of the supply pressure, the upward force of the supply pressure acting beneath the clapper overcomes the lever-applied force thereby opening the clapper.

Once the clapper has opened, the lever acts as a latch, preventing the clapper from returning to the closed position. Water from the supply flows through the Deluge Valve into the system piping. Water also flows through the Deluge Valve alarm outlet to the alarm devices.

After system shutdown, resetting the Model DDX Deluge Valve is quite simple. Doing so only requires pushing in and turning the reset knob at the rear of the valve (see Fig 1). The external reset feature of the Model DDX Deluge Valve provides a means for simple, economical system testing, which is one essential facet of a good maintenance program. The external reset feature does not, however, eliminate another important facet of good maintenance, namely, periodic cleaning and inspection of the internal valve parts.

In the event that water builds up inside the valve due to condensate from the air supply system or water left inside from valve system testing, a drain is available for venting. After closing the main supply valve, a small valve over the drain cup can be opened slightly until the water inside the valve body and the main pipe column has drained. See the section titled "Draining Excess/Condensate Water From System" in this bulletin for the detailed procedure. The Model B Manual Emergency Station (see Fig. 3) is also included in the Reliable Type D Double Interlock Preaction System trim set. It consists of an aluminum nameplate mechanically attached to a ball valve. The valve handle in its OFF position is guarded against accidental turning to the ON position (and system discharge) by a nylon cable tie provided with each trim kit. The cable tie is inserted, as shown in Fig. 3, after the system has been restored for operation. The nylon cable tie is designed to allow, in case of an emergency, forceful turning of the valve handle to the ON position. As an alternative to the Model B Hydraulic Manual Emergency Station, the Model A Hydraulic Manual Emergency Pull Box (see Reliable Bulletin 506) is

also available and can be provided as an option.

Whenever ambient temperature conditions are high, the water temperature in the Model DDX Deluge Valve's push-rod chamber could possibly increase, thereby increasing the pressure in the chamber to values exceeding the rated pressure of the system. In an indoor installation where standard room temperatures are exceeded, a pressure relief kit may be needed. Pressure relief kit, P/N 6503050001, can be installed into the pushrod chamber's releasing line to limit the pressure to 175 psi (12,1 bar).

Pressurizing Line Connection

The water supply for the push-rod chamber must be provided by connection of its inlet pressurizing line to the water supply piping. Pressurizing lines for multiple Model DDX Deluge Valve push-rod chambers must never be manifolded together, having only a single tap on the water supply piping. Each Model DDX Deluge Valve must have its own push-rod chamber pressurizing line connection. This connection must be made on the supply side of the main water supply control valve. This can be accomplished by:

- Using a tapped connection directly below or next to the main water supply control valve using a welded outlet or the appropriate mechanical fittings. A grooved-end outlet coupling is one way to achieve this; or
- Using a water supply control valve that has an available threaded (NPT) supply-side tap design to allow for a direct water supply connection to the Model DDX Deluge Valve's push-rod chamber.

Caution: Reliable's DDX valve is designed with an inlet restriction built into the pushrod chamber. It is important not to introduce additional restrictions into the direct water supply connection or the discharge from the pushrod chamber by installing additional valves or improperly installing the copper lines used in the trim of the valve.

Hydrostatic Testing of DDX Valves and DDX Systems

As required by NFPA 13, fire sprinkler systems with working pressures up to and including 150 psi are to be hydrostatically tested at a water pressure of 200 psi and maintain that pressure without loss for two hours. Fire sprinkler systems with working pressures above 150 psi are required to be hydrostatically tested at 50 psi above the system working pressure and maintain that pressure without loss for two hours. In addition to the hydrostatic tests described above, dry pipe and double interlock preaction systems require an additional low pressure air test. In some cases, hydrostatic testing (in accordance with the NFPA 13 requirements noted above) will result in pressures that exceed the working pressure of the valve and trim kit for the two-hour test period.

TYPE D DOUBLE INTERLOCK PREACTION TRIM

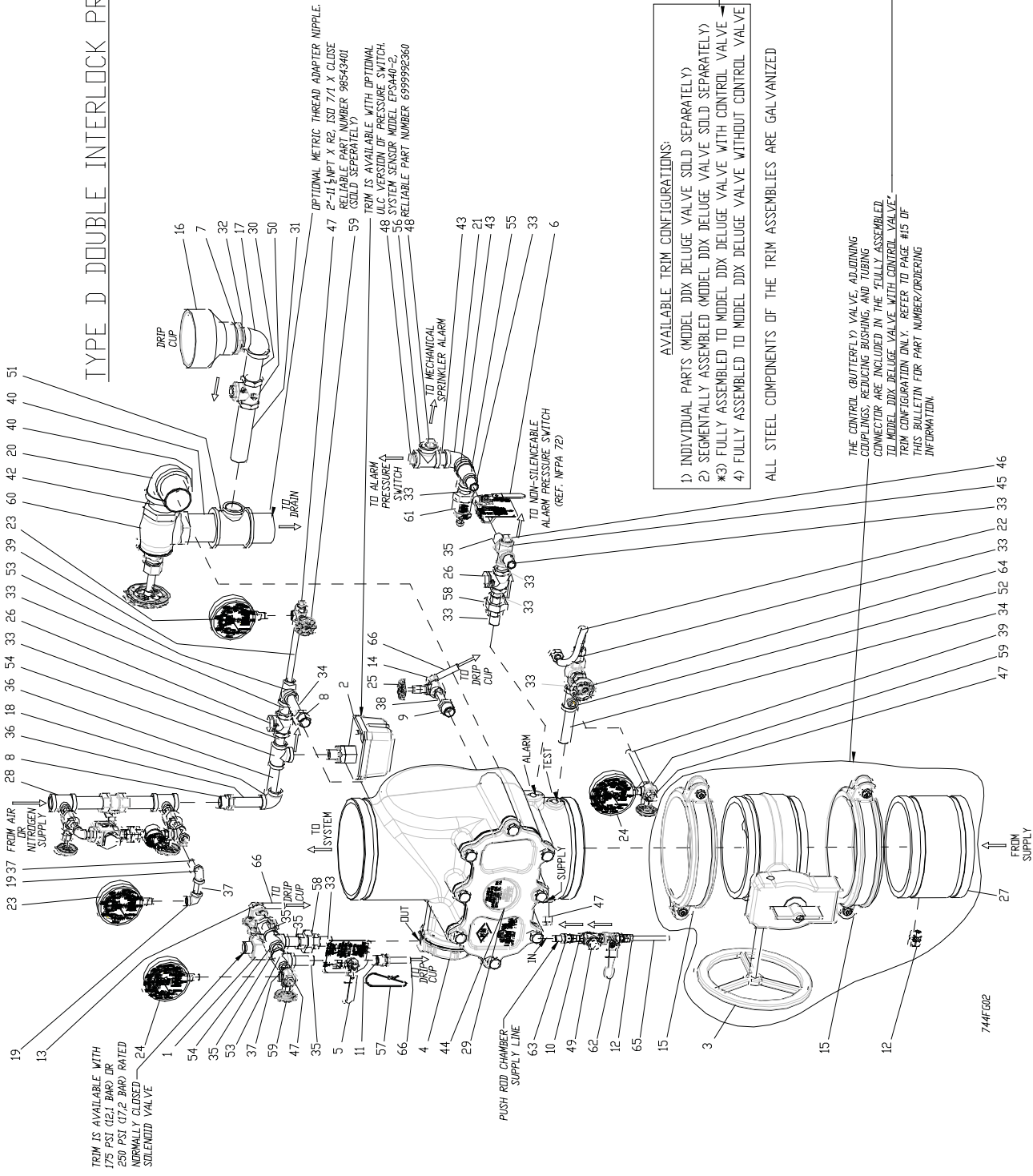

TRIM IS AVAILABLE WITH 175 PSI (2.1 BAR) OR 250 PSI (17.2 BAR) RATED NORMALLY CLOSED SOLENOID VALVE

OPTIONAL METRIC THREAD ADAPTER NIPPLE.
 2"-11 5/16" MPT X R2, ISO 7/1 X CLOSE
 RELIABLE PART NUMBER 98543401
 (SOLD SEPARATELY)
 TRIM IS AVAILABLE WITH OPTIONAL
 ULC VERSION OF PRESSURE SWITCH
 SYSTEM SENSOR MODEL EPS340-2,
 RELIABLE PART NUMBER 699992360

AVAILABLE TRIM CONFIGURATIONS:
 1) INDIVIDUAL PARTS (MODEL DDX DELUGE VALVE SOLD SEPARATELY)
 2) SEGMENTALLY ASSEMBLED (MODEL DDX DELUGE VALVE SOLD SEPARATELY)
 *3) FULLY ASSEMBLED TO MODEL DDX DELUGE VALVE WITH CONTROL VALVE
 4) FULLY ASSEMBLED TO MODEL DDX DELUGE VALVE WITHOUT CONTROL VALVE

ALL STEEL COMPONENTS OF THE TRIM ASSEMBLIES ARE GALVANIZED

THE CONTROL (BUTTERFLY) VALVE, ADJOINING COUPLINGS, REDUCING BUSHING, AND TUBING CONNECTOR ARE INCLUDED IN THE FULLY ASSEMBLED TO MODEL DDX DELUGE VALVE WITH CONTROL VALVE TRIM CONFIGURATION ONLY. REFER TO PAGE #15 OF THIS BULLETIN FOR PART NUMBER/ORDERING INFORMATION.

744FG02

Fig. 2

Type D Double Interlock Preaction System Parts List (Refer to Fig. 2)

ITEM NO.	PART NO.	DESCRIPTION	QTY.
1	6871020000	Valve, Solenoid, Parker, 175 PSI	1
	6871020020	Valve, Solenoid, Parker, 250 PSI	
2	6999991212	Switch, Pressure (EPS10-2), UL/FM	1
	6999992360	Switch, Pressure (EPSA10-2), ULC	
3	6215053200	8" UL/FM Butterfly Valve	1
4	6103080001	Assembly, Duluge Dry Valve	1
5	78653000	Assembly, Manual Emergency Station	1
6	78653004	Assembly, Valve Caution Station, 1/2"	1
7	98048015	Bushing, Reducer, 2" Spigot x 1" NPTF, PVC	1
8	98048022	Bushing, Reducer, 3/4" x 1/2", Galv.	2
9	98048025	Bushing, Reducer, 3/4" x 1/4", Galv.	1
10	98840147	Check Valve, 1/4" NPT, Poppet Type Inline	1
11	92056810	Connector, 3/8" ID Tube x 1/2" NPT	1
12	92056702	Connector, 3/8" Tubing x 1/4" NPT	2
13	92056704	Connector, Elbow, 3/8" Id Tube x 1/2" NPT	1
14	92056705	Connector, Elbow, 3/8" ID Tube x 1/4" NPT	1
15	7G05323200	Coupling, Rigid, 8"	2
16	98050004	Drain Cup, PVC	1
17	98174403	Ell, 1", Mall Iron, Galv.	1
18	98174401	Ell, 1/2", Mall Iron, Galv.	1
19	98174404	Ell, 1/4", Mall Iron, Galv.	2
20	98174405	Ell, 2", Mall Iron, Galv.	1
21	98174402	Ell, 3/4", Mall Iron, Galv.	1
22	96920912	Flex Line, 12"	1
23	98248000	Gauge, Air Pressure (0-80 PSI)	2
24	98248001	Gauge, Water Pressure (0-300 PSI)	2
25	98840172	Globe Valve, 1/4"	1
26	98840181	Horiz. Swing Check Valve, 1/2" NPT	2
27	91004288	Manifold, Supply, 8"	1
28	6304000100	Mod. A-2 Auto Air Maintenance Device, 10psi	1
29	94616917	Nameplate, Single Interlock	1
30	98543222	Nipple, Steel, Galv., 1" x 3-1/2"	1
31	98543266	Nipple, Steel, Galv., 1" x 6"	1
32	98543213	Nipple, Steel, Galv., 1" x Close	1
33	98543223	Nipple, Steel, Galv., 1/2" x 1-1/2"	11

ITEM NO.	PART NO.	DESCRIPTION	QTY.
34	98543216	Nipple, Steel, Galv., 1/2" x 3-1/2"	2
35	98543209	Nipple, Steel, Galv., 1/2" x 2"	5
36	98543230	Nipple, Steel, Galv., 1/2" x 3"	2
37	98543226	Nipple, Steel, Galv., 1/4" x 1-1/2"	3
38	98543225	Nipple, Steel, Galv., 1/4" x 2-1/2"	1
39	98543217	Nipple, Steel, Galv., 1/4" x 6"	2
40	98543262	Nipple, Steel, Galv., 2" x 3-1/2"	2
41	-----	-----	--
42	98543238	Nipple, Steel, Galv., 2" x Close	1
43	98543279	Nipple, Steel, Galv., 3/4" x Close	2
44	99080002	Pad-adhesive	1
45	98750003	Pipe Cross, 1/2", Galv.	1
46	98604406	Plug, Iron, Sq. Hd., 1/2"	1
47	98614403	Plug, Iron, Sq. Hd., 1/4"	4
48	98614401	Plug, Iron, Sq. Hd., 3/4"	2
49	98727607	Strainer, 1/4"	1
50	98840145	Swing Check Valve, 1" NPT	1
51	96606627	Tee, Glvn, 2" x 2" x 1"	1
52	96606607	Tee, Glvn., 1/2" x 1/2" x 1/4"	1
53	98761649	Tee, Glvn., 1/2 x 1/4 x 1/2	2
54	98761651	Tee, Glvn., 1/2"	2
55	96606612	Tee, Glvn., 3/4" x 1/2" x 1/2"	1
56	96606601	Tee, Glvn., 3/4"	1
57	89141112	Tie, Retaining	9
58	98815200	Union, 1/2", Iron, G.J., Galv.	2
59	98840160	Valve, 3-way, 1/4"	3
60	98840100	Valve, Angle, 2"	1
61	78653100	Valve, Ball Drip, 1/2"	1
62	98840117	Valve, Ball, 1/4" NPTF x 1/4" NPTM	1
63	98840187	Valve, Check, 1/4" NPTF x 1/4" NPTM	1
64	98840171	Valve, Globe, 1/2"	1
65	96686722	Tubing, Copper, 3/8" O.D. x 2 Ft.	1
66	96686754	Tubing, PVC, 3/8" I.D. x 6 Ft.	1

MODEL B HYDRAULIC MANUAL EMERGENCY STATION

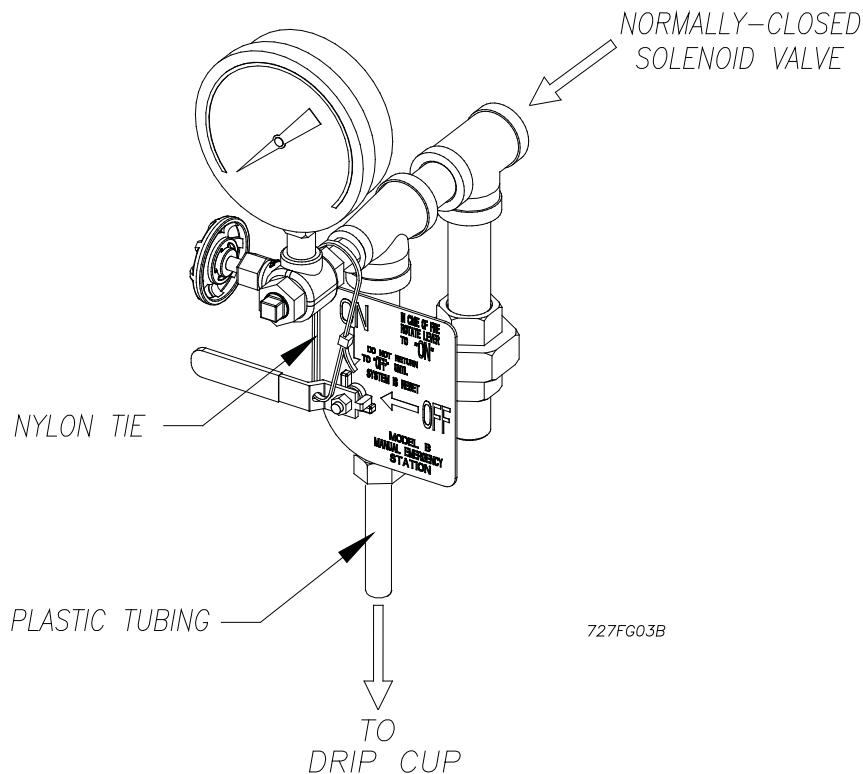

Fig. 3

The valve and applicable trim kit have been tested, approved and listed under these conditions and as such, hydrostatic testing in accordance with NFPA 13 is acceptable. In addition, the clapper can remain in the closed position and the trim kit need not be isolated, as each has been designed to withstand hydrostatic testing as required by NFPA 13.

Hydrostatically testing the valve and trim to pressures higher than their rating is limited to the hydrostatic test as referenced by NFPA 13. It does not address the occurrence(s) of a "water hammer" effect, which can indeed damage the valve. A "water hammer" in the water supply piping of the valve can create pressures in excess of the rated pressure and should be avoided by all necessary means. This condition may be created from improper fire pump settings, underground construction work, or an improper venting of trapped air in the water supply piping.

System Design Considerations

The automatic sprinklers, air compressor, releasing devices, electric releasing control equipment, fire detection devices, manual pull stations, and signaling devices which are utilized with the Type D Double Interlock Preaction System must be UL or ULC Listed or FM Approved, as applicable.

Factory Mutual requires that detection devices in refrigerated areas be of the fixed temperature type. In addition, they must have a temperature rating lower than that of the sprinklers and preferably, as low as possible for the given ambient conditions.

The Deluge Valve, and all interconnecting piping must be located in a readily visible and accessible location and in an area that can be maintained at a minimum temperature of 40°F (4°C). **Note:** Heat tracing is not permitted.

Pendent sprinklers, other than dry pendants, used on preaction systems shall be installed on return bends per NFPA 13.

The solenoid valve is operated and supervised by the electrical releasing/control panel. Details on the electrical portion of this system can be found in Reliable Bulletin 700, "Special Hazards & Special Systems."

System Air Pressure Requirements

In accordance with NFPA 13, double interlock preaction systems require a minimum of 7 psi (0,5 bar) pneumatic pressure to supervise the sprinkler system. The Model A-2 Pressure Maintenance Device is used to maintain the system pneumatic pressure between 7 and 10 psi (0,5 and 0,7 bar) where a dry nitrogen gas supply or a clean, dependable, and continuous (24 hours per day, 7 days per week) compressed air source is available.

To adjust the system pneumatic pressure between 7 and 10 psi (0,5 and 0,7 bar) refer to Reliable Bulletin 251. The low air pressure alarm switch (Item #5, Fig. 2) is factory set to operate between 5 and 6 psi (0,3 and 0,4 bar) with decreasing pressure. If necessary, adjustments can be made by following the manufacturer's adjustment procedure as described in the installation and maintenance instructions enclosed with the switch.

Note: The dew point of the air must be maintained below the lowest ambient temperature to which the double interlock system piping will be exposed. Introduction of moisture into the system piping that is exposed to freezing temperatures can create ice blockage, which could prevent proper operation of the system. As minimum the supply of air should be taken from refrigerated area at the lowest temperature. The air supply system must be carefully designed to prevent plugging by frost deposits. Special requirements such as those in FME&R'S "Installation Guidelines for Refrigerated Storage" may need to be incorporated.

Whenever multiple Praction Systems are installed at the same location, it is strongly recommended that each system have its own Model A-2 Pressure Maintenance Device for individual maintenance of air pressure.

System Electrical Requirements

All releasing and detection devices in Type D Double Interlock Praction Systems are operated and supervised by the Potter PFC-4410-RC Releasing/Control Panel in accordance to the wiring diagram shown in fig. 4. The Releasing/ Control Panel should be set to use Program #11 (see Potter Instruction Manual #5403550).

The power supply, the standby emergency power supply, battery charger, and the rectifier circuitry are all contained within the Potter PFC-440-RC Releasing/ Control Panel. Batteries that provide ninety hours of standby power are required for FM Approved systems.

The Model BNG-1 Manual Emergency Station can be connected as a simple detector for fire annunciation, or the Model BNG-1F can be connected to both zones for total system emergency manual operation.

The solenoid valve is operated and supervised by the Potter PFC-4410-RC Releasing/Control Panel. The Potter PFC-4410-RC Releasing/Control Panel requires 120 VAC.

Caution: Repairs or disassembly of the solenoid valve should only be done by a trained technician. An improperly repaired or partially assembled solenoid valve could result in failure of the valve to operate.

Double Interlock Praction System

Electric/Electric Actuation (Type D)

Engineering Specifications

General Description

Praction system shall be a double interlock praction system utilizing an 8" (200mm) Reliable Model DDX Deluge Valve. Deluge Valve shall be an [8" (200mm)] [cULus Listed] [Factory Mutual Approved] hydraulically operated, differential latching clapper-type valve. Deluge valve construction shall be of lightweight, ductile-iron construction with "screw in" stainless steel seat and clapper assembly. Stainless steel seat shall have O-ring seals to resist leakage and corrosion. Clapper facing shall be pressure actuated, providing a limited compression seat for the sealing force between the clapper rubber facing and the valve seat. Deluge valve shall have an external reset knob for resetting the clapper without requiring the removal of the

valve face plate. Push-rod chamber design shall consist of a stainless steel piston/ push-rod and spring assembly with diaphragm seal secured to the casting through a push-rod guide constructed of a synthetic engineering plastic to resist corrosion. Casting shall have a bleeder hole located on the pushrod chamber for air/water leakage indication. Trip ratio shall be approximately a 3:1 force differential. Deluge valve shall be of the straight through design to minimize friction loss and be capable of being reset without having to remove the valve cover plate through the use of an external reset knob. Inlet restriction orifice shall be factory installed into the inlet port of the deluge valve push-rod cover plate and not be a separate part of the deluge valve trim. End connection style to be [8" (200mm)] grooved inlet and grooved outlet, per ANSI/AWWA C606. Deluge valve shall have a rated working pressure of 250 psi (17,2 bar) and shall be factory hydrostatic tested at 500 psi (34,5 bar). Deluge valve to be [8" (200mm)] Reliable Model DDX Deluge Valve (Bulletin 515).

Valve trim shall be Type D electric/electric release trim consisting of the following components:

- Hydraulic trim shall be galvanized and brass components specifically Listed/Approved with the deluge valve, including associated pressure gauges, 2" (50 mm) drain connection, alarm device, alarm test, and pushrod chamber connections.
- Electrical two-way, normally-closed, pilot-operated solenoid valve [cULus Listed] [FM Approved] for its intended use. The solenoid valve shall be constructed of a brass body with stainless steel sleeve tube, springs, stop and plunger, and with ½" female NPT end connections. Solenoid valve shall have a maximum working pressure of [175 psi (12,1 bar)] [250 psi (17,2 bar)] and maximum ambient temperature rating of 150°F (66°C). Power consumption of integrated coil shall be limited to [10watts (175 psi (12,1 bar) Rated)] [22 watts (250 psi (17,2 bar) Rated)] and require 24 VDC from a releasing/control panel listed for such service. Solenoid valve shall be a Skinner ½" normally-closed solenoid valve, [Model 73218BN4UNLVNOC111C2 (175 psi (12,1 bar) Rated)] [Model 73212BN4TNLVNOC322C2 (250 psi (17,2 bar) Rated)].
- Low air pressure switch to indicate loss of air pressure in system piping. Pressure switch shall be [cULus Listed] [FM Approved] and of the bellows- activated type enclosed in a weatherproof, 4x, NEMA 4-rated enclosure incorporating tamper-resistant screws. There shall be two sets of SPDT (Form C) contacts rated at 10.0 A @ 125/250 VAC and 2.5 A @ 6/12/24 VDC. The pressure switch shall have a maximum service pressure rating of 250 psi (17,2bar) and shall be factory adjusted to operate at a pressure of 4 to 8 psi (0,27 to 0,55 bar) with adjustment up to 20 psi (1,3 bar). Switch shall be provided with a ½" NPT male pressure connection. Low air alarm pressure switch shall be System Sensor EPS10-2.

- Pressure maintenance device for maintaining a constant system pneumatic pressure regardless of pressure fluctuations in the compressed air (or nitrogen) source. The pressure maintenance device shall consist of galvanized trim and brass parts, including a strainer, a field adjustable air pressure regulator, and associated pressure gauge. The pressure regulator shall have an adjustable outlet pressure range of 5 to 50 psi (0,34 to 3,4 bar). The pressure maintenance device shall have a working pressure rating of 175 psi (12,1 bar). Recommended pneumatic supervisory pressure shall be 10 psi (0,70 bar). Pressure maintenance device shall be Reliable Model A-2.

Double Interlock Preaction System shall be a Reliable Double Interlock Type D Preaction System, Bulletin 744.

Pneumatic Supervisory Pressure Supply Options

Owner's Air supply

Air supply shall be provided by an owner-supplied air system.

Compressed Air Supply

Air supply shall be provided by an automatic tank-mounted air compressor sized (appropriate hp) for the capacity (volume) of the sprinkler system piping, and be capable of restoring normal air pressure in the system within 30 minutes. Tank mounted compressor shall be a motor mounted, oil-less, piston compressor, including gauge, pressure switch, check valve, drain valve, and safety relief valve. Single-phase motor shall have internal thermal protection.

Nitrogen

Nitrogen cylinders provided by an approved source shall provide the nitrogen supply. The nitrogen cylinder pressure shall be regulated and supervised through the use of nitrogen regulating device and low-pressure trim kit. This device shall consist of a brass, single stage pressure regulator, equipped with high pressure inlet and low pressure outlet gauges, and 1/4" copper connection tubing with galvanized 3/4" x 1/4" reducer bushing. Optional: Low-pressure trim kit shall be included to monitor the regulated nitrogen supply pressure to provide a low-pressure supervisory alarm. This kit shall include a low-pressure switch with associated galvanized connection trim. Assembly shall be a Reliable Nitrogen Regulating Device This device is to be used in conjunction with the Reliable Model A-2 Pressure Maintenance Device.

Optional System Accessories

System Control Valve

Preaction system control valve shall be a slow close, [cULus Listed] [FM Approved] indicating butterfly type valve with a pre-wired supervisory tamper switch assembly. The valve shall be rated for a working pressure of [300 psi (20,7 bar)]. System control valve shall be an [8" (200 mm)] Nibco GD-4765-8N Butterfly Valve.

Detection System

To initiate actuation of the preaction system's deluge valve, a supplemental electric detection system shall be provided [Insert applicable product specification].

Releasing/Control Panel

A releasing/control panel shall be used to operate the preaction system. The releasing/ control panel shall be a conventional, microprocessor-controlled panel containing two initiating device circuits, and waterflow and supervisory inputs. Output circuits shall include alarm, waterflow, supervisory, and releasing circuits. Mode of operation shall be set for cross-zoned operation, requiring both a detection device input and a low air pressure switch input (sprinkler operation) to energize the solenoid valve, causing the deluge valve to actuate. Releasing/control panel shall be equipped with a local tone alarm to annunciate loss of AC power, system trouble, circuit trouble, and low auxiliary DC power supply. Panel shall be [cULus Listed] [FM Approved] and be capable of providing power for compatible detectors and auxiliary devices used. Audible alarms shall be able to be silenced at releasing panel. Auxiliary DC power supply shall consist of (2) 12-volt lead acid batteries of the same ampere-hour rating, providing [60 hours – cULus Listed] [90 hours – FM Approved]. Dry contacts shall be provided for remote annunciation of alarm, trouble, and supervisory panel signals. Main power supply to be a dedicated 120 VAC / 60 Hz circuit.

Waterflow Alarm Pressure Switch

Alarm pressure switch shall be provided to indicate water flow and provide a water flow alarm. Pressure switch shall be [cULus Listed] [FM Approved] and of the bellows activated type enclosed in a weatherproof, 4x, NEMA 4-rated enclosure incorporating tamper-resistant screws. There shall be two sets of SPDT (Form C) contacts rated at 10.0 A @ 125/250 VAC and 2.5 A @ 6/12/24 VDC. The pressure switch shall have a maximum service pressure rating of 250 psi (17,2 bar) and shall be factory adjusted to operate at a pressure of 4 to 8 psi (0,27 to 0,55 bar) with adjustment up to 20 psi (1,3bar). Switch shall be provided with a 1/2" NPT male pressure connection. Waterflow alarm pressure switch shall be System Sensor EPS10-2.

Technical Data

Reliable Wet Pilot Line Single Interlock Preaction Systems, with associated trim, size 8" (200mm) is rated for use at minimum water supply pressure of 20 psi (1,4 bar) and maximum supply pressure of 250 psi (17,2 bar). Water supplied to the inlet of the valve and to the pushrod chamber must be maintained between 40°F (4°C) and 140°F (60°C).

The following list of technical bulletins pertains to valves and devices that may be used in this preaction system:

Deluge Valve	Reliable 514/515
Hydraulic Emergency Station (Model A)	Reliable 506
Solenoid Valve	Reliable 718
Mechanical Sprinkler Alarm	Reliable 612/613
Pressure Maintenance Device	Reliable 250/251/253
Nitrogen Regulating Device	Reliable 253
Air Compressor	Reliable 700
Releasing/Control Panel	Potter 5403550
Electric Emergency Station	Reliable 700
Thermal Detectors	Reliable 722
Fire Alarm Devices	Reliable 700
Low Air Pressure Supervisory Switch	System Sensor A05-0176
Waterflow Pressure Alarm Switch	System Sensor A05-0176

TYPE D DOUBLE INTERLOCK PREACTION SYSTEM ELECTRICAL CONNECTIONS

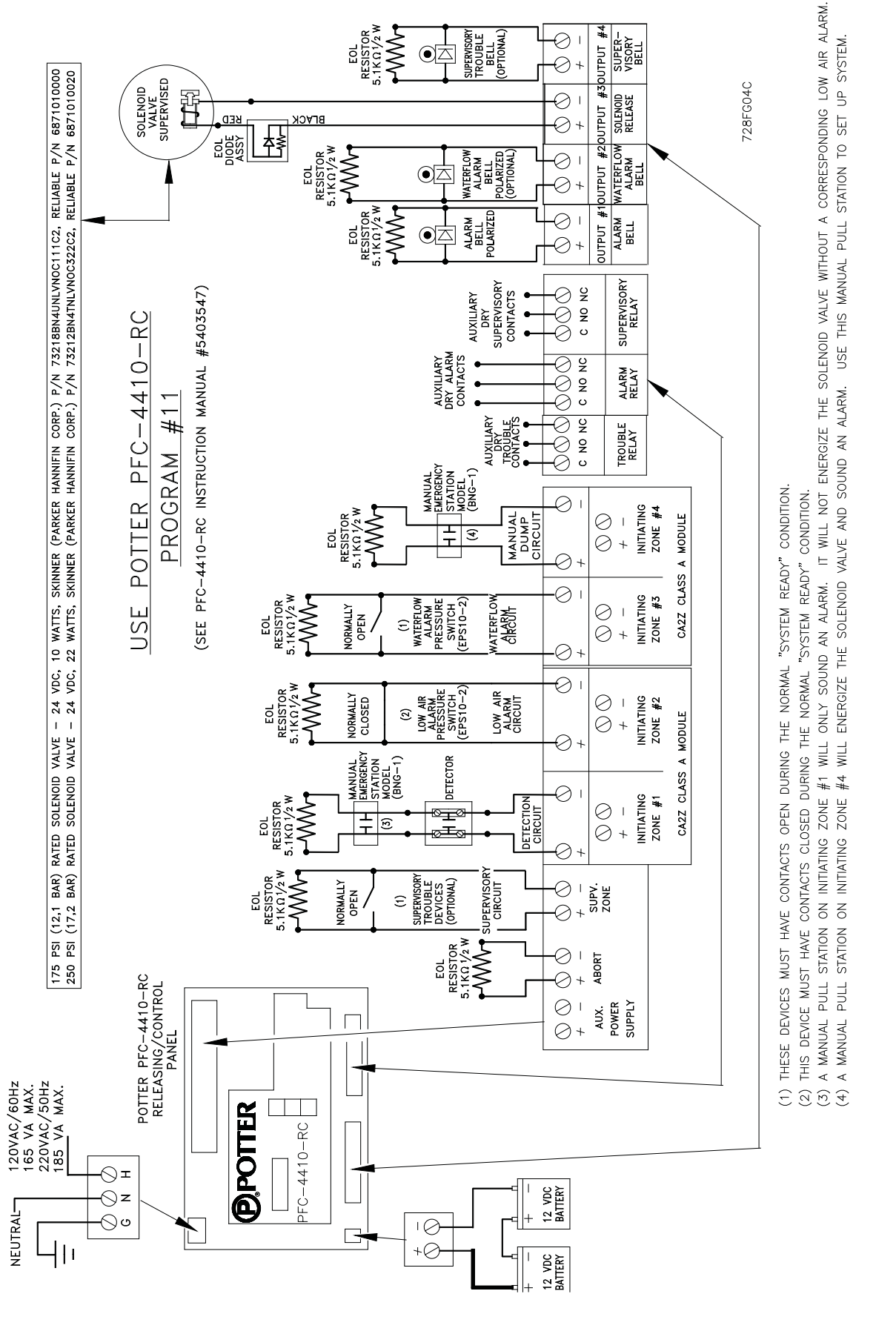

175 PSI (12.1 BAR) RATED SOLENOID VALVE - 24 VDC, 10 WATTS, SKINNER (PARKER HANNIFIN CORP.) P/N 73218BN4UNLVNOC111C2, RELIABLE P/N 6871010000
 250 PSI (17.2 BAR) RATED SOLENOID VALVE - 24 VDC, 22 WATTS, SKINNER (PARKER HANNIFIN CORP.) P/N 73212BN4TNLVNOC322C2, RELIABLE P/N 6871010020

- (1) THESE DEVICES MUST HAVE CONTACTS OPEN DURING THE NORMAL "SYSTEM READY" CONDITION.
- (2) THIS DEVICE MUST HAVE CONTACTS CLOSED DURING THE NORMAL "SYSTEM READY" CONDITION.
- (3) A MANUAL PULL STATION ON INITIATING ZONE #1 WILL ONLY SOUND AN ALARM. IT WILL NOT ENERGIZE THE SOLENOID VALVE WITHOUT A CORRESPONDING LOW AIR ALARM.
- (4) A MANUAL PULL STATION ON INITIATING ZONE #4 WILL ENERGIZE THE SOLENOID VALVE AND SOUND AN ALARM. USE THIS MANUAL PULL STATION TO SET UP SYSTEM.

Fig. 4

Model DDX Valve Description

1. Rated working pressure:
Valve & System - 250 psi (17.2 bar).
2. Factory tested to a hydrostatic pressure of 500 psi (34,5 bar). (Valve only)
3. End and trim connections:
 - ANSI/AWWA C606 grooved inlet and outlet

Groove Dimension			
Outlet Diameter	Groove Diameter	Groove Width	Outlet Face to Groove
8.625" (219mm)	8.441" (214mm)	7/16" (11mm)	3/4" (19mm)

- Threaded openings Per ANSI B 2.1
 - Valve Exterior's Color: Black
4. Face to face dimensions:
 - 19 3/8" (492 mm)
 5. Shipping weight:
 - 148 lbs (67.3 kg)
 6. Friction loss (Expressed in equivalent length of Schedule 40 pipe, based on Hazen & Williams formula with C=120)
 - 53.5 ft (16.31 m)
 7. Installation position: Vertical

Maintenance

Reliable Double Interlock System and associated equipment shall periodically be given a thorough inspection and test. NFPA 25 "Inspection, Testing and Maintenance of Water Based Fire Protection Systems" provides minimum maintenance requirements. The double interlock system shall be tested, operated, cleaned and inspected at least annually and parts replaced as required.

Resetting the Type D Double Interlock

Preaction System

Refer to Figs. 2, 5, and 6.

1. Close the main valve controlling water supply (Fig. 6) to the Deluge Valve and close the 1/4" globe valve controlling system air pressure in the Model A-2 Pressure Maintenance Device.
2. Close the pushrod chamber supply valve; valve A (Fig. 6).
3. Open the main drain valve, valve B (Fig. 6), and drain system.
4. Open all drain valves and vents at low points throughout the system, closing them when flow of water has stopped. Open valve D (Fig. 6).

Note: The above steps accomplish the relieving of pressure in the pushrod chamber of the Deluge Valve.

5. With valve G (Fig. 6) open, push in the plunger of ball drip valve, valve E (Fig. 6), to force the ball from its seat, and drain any water in the alarm line.

6. With the Model B Manual Emergency Station, valve D (Fig. 6), open, push in and rotate the Deluge Valve's external reset knob (#14, Fig. 5) clockwise until you hear a distinct clicking noise, indicating that the clapper has closed. **Note:** The reset knob can be rotated only while pressure in the pushrod chamber is vented to atmospheric conditions (0 psig).
7. Inspect and replace any portion of the sprinkler system subjected to fire conditions.
8. Open valve A (Fig. 6) and allow water to fill the Deluge Valve's pushrod chamber. Close valve D (Fig. 6).
9. Bleed any air from the actuation piping by energizing the solenoid valve. This is done by operating a detector or an electric manual emergency station. While water is flowing through the solenoid valve, cause it to close. Refer to Bulletin 700, "Special Hazards & Special Systems" for details.
Note: All detection devices must be reset before the releasing/control panel can be reset.
10. Close valve G (Fig. 6). Open the 1/4" globe valve in the Model A-2 Pressure Maintenance Device to restore air pressure in the sprinkler system.
11. Open valve G (Fig. 6). Open slightly the main valve controlling water supply (Fig. 6) to the Model DDX Deluge Valve, closing drain valve B (Fig. 6) when water flows. Observe if water leaks through the ball drip valve, valve E (Fig. 6), into the drip cup, J (Fig. 6). If no leak occurs, the Deluge Valve's clapper is sealed. Open slowly, and verify that the main valve controlling water supply is fully opened and properly monitored.
12. Verify that valve A (Fig. 6) and valve G (Fig. 6) are open.
13. Secure the handle of the Model B Manual Emergency Station, valve D (Fig. 6), in the OFF position with a nylon tie (#57, Fig. 2).

Inspection and Testing

Refer to Figs. 2, 5, and 6.

1. **Water supply** — be sure the valve(s) controlling water supply to the Deluge Valve are opened fully and properly monitored.
2. **Alarm line** — be sure that valve G (Fig. 6) is opened and remains in this position.
3. **Other trimming valves** — check that valve A (Fig. 6) is open as well as all of the pressure gauge's 1/4" 3-way valves. Valves D, F, and H (Fig. 6) should be closed.
4. **Ball drip valve E (Fig. 6)** — make sure that valve G (Fig. 6) is open. Push in on the plunger to be sure the ball check is off its seat. If no water appears, the Deluge Valve's water seat is tight. Inspect the bleed hole (see Fig. 5) on the underside of the pushrod chamber for leakage.
5. **System pneumatic pressure** — check that system air pressure is between 7 and 10 psi (0,5 bar 0,7 bar). Check the Model A-2 Pressure Maintenance Device for leakage and proper pressure.

MODEL DDX VALVE 8"(200MM)

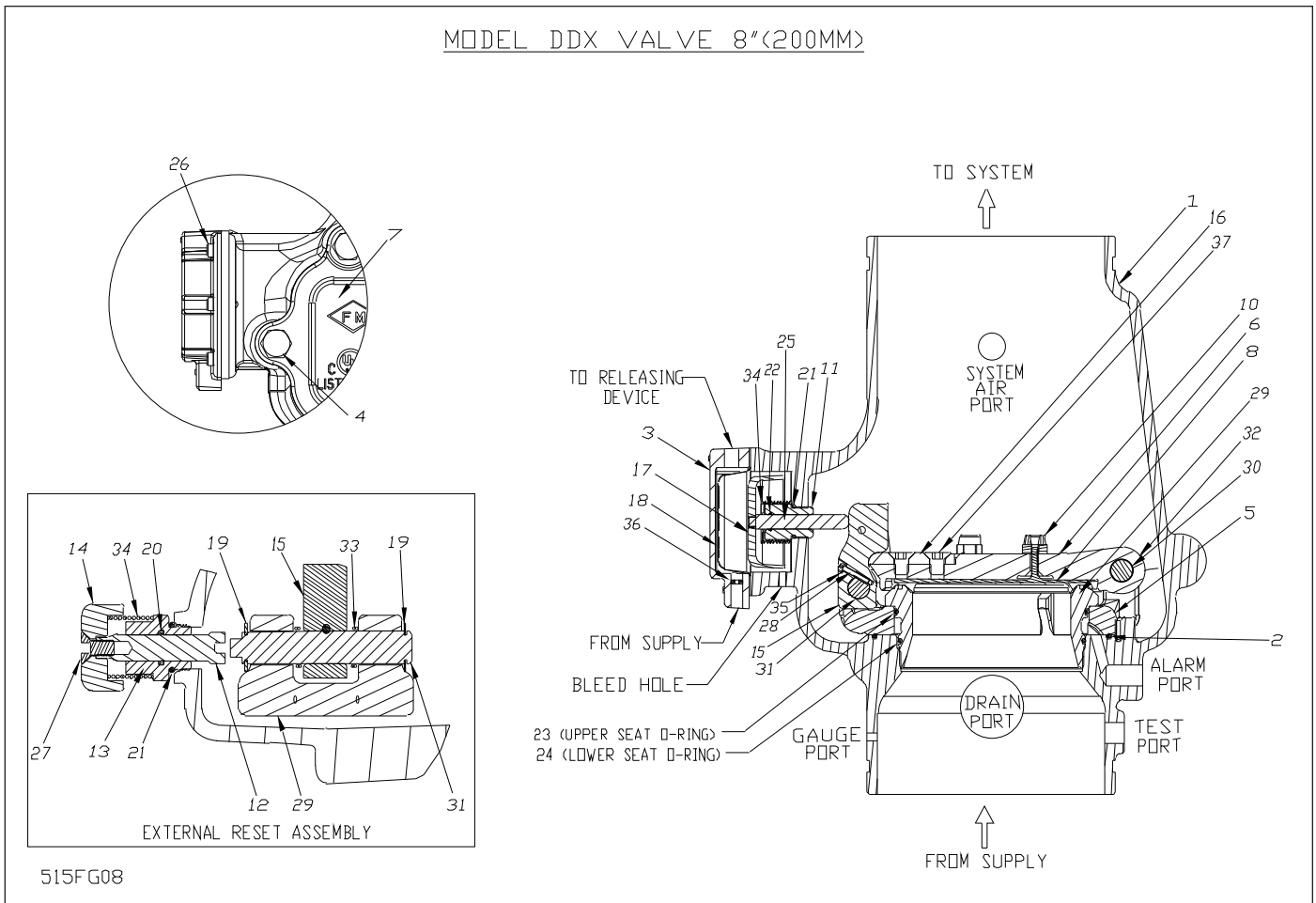

Fig. 5

Model DDX 8" (200mm) Deluge Valves Parts List (Refer to Fig. 5)

ITEM NO.	PART NUMBER	PART DESCRIPTION	NO. REQ'D
1	91006028	Body	1
2	95406414	O-Ring, (266)	1
3	92126006	Cover, Pushrod	1
4	95606110	Screw, Hex Cap, 5/8-11 x 2", ZN PLTD, Grade A	8
5	91306018	Mounting Ring	1
6	91916008	Clapper	1
7	92116068	Cover, Access	1
8	93416008	Seal Assembly	1
9	93706008	Gasket, Access Cover (Not Shown)	1
10	93722000	Bumpstop Assembly	3
11	93916006	Pushrod Guide	1
12	93916066	Shaft, Reset	1
13	94106066	Housing, Reset	1
14	94356006	Knob, Reset	1
15	94506008	Lever	1
16	95006410	Striker, Lever/Clapper	1
17	95106006	Piston	1
18	95276006	Diaphragm	1
19	95316408	Clip, Retaining, 3/4" Shaft, SS	4
20	95406007	O-Ring, (114)	1
21	95406024	O-Ring, (912)	2
22	95406407	O-Ring, (014)	1

ITEM NO.	PART NUMBER	PART DESCRIPTION	NO. REQ'D
23	95406413	O-Ring, (260)	1
24	95406412	O-Ring, (259)	1
25	95506006	Pushrod	1
26	95606114	Screw, Socket Head, 1/4-20 x 5/8"	6
27	95606127	Screw, Socket Cap, Flat Head, 3/8-16 x 3/4"	1
28	95606130	Screw, Socket Head, #10-23 x 1", SS	1
29	96016008	Seat	1
30	96206008	Pin, Hinge	1
31	96216008	Pin, Lever	1
32	96310008	Spacer, Clapper	2
33	96406008	Spring, Lever	1
34	96406906	Spring, DDX	2
35	96906111	Washer, Spring Lock, #10, SS	1
36	94206406	Inlet Orifice	1
37	95606135	Screw, Socket Cap, Flat Head, 1/2-13 x 3/4", SS	2
38	94616921	Label, Caution, Knob (Not Shown)	1
39	91556922	Ball Chain, 1/8" (Not Shown) (Length in Inches)	6
40	91556923	Clamping Link, Ball Chain, (Not Shown)	1

6. **Releasing device** — check outlet of the releasing device (i.e., solenoid valve or the Model B Manual Emergency Station, valve D (Fig. 6)) for leakage. Also verify that tubing drain lines from releasing devices are not pinched or crushed which could prevent proper releasing of the Deluge Valve.
7. **Testing alarms** — make sure that valve G is open. Open valve F (Fig. 6) permitting water from the supply to flow to the electric sprinkler alarm switch and to the mechanical sprinkler alarm (water motor). After testing, close this valve securely. Push in on the plunger of ball drip valve E (Fig. 6) until all of the water has drained from the alarm line.
8. **Operational test** — Open the Model B Manual Emergency Station, valve D (Fig.6), or operate by electrical actuation (refer to Bulletin 700, “Special Hazards & Special Systems” for details). Note: An operational test will cause the Deluge Valve to open and flow water into the sprinkler system.
9. Secure Model B Manual Emergency Station, valve D (Fig. 6), in the OFF position with a nylon tie (#57, Fig. 2) after the Deluge Valve is reset.

Testing the Model DDX Deluge Valve Without Flowing Water

Refer to Fig. 6

1. Close the valve controlling water supply to Deluge Valve and open the main drain valve B.
2. Verify that valve A is open, allowing water to enter the pushrod chamber.
3. Operate detection systems – energize the solenoid valve by operating both a detector and the low air pressure switch (refer to Bulletin 700, “Special Hazards & Special Systems” for details).
4. Operation of the detection system will result in a sudden drop of water pressure in the push rod chamber.
5. Reset detection system—reverse operations performed in step three above and then proceed according to the directions listed in the “Resetting the Type D Double Interlock Preaction System” section of this bulletin for resetting the Deluge Valve.

Draining Excess/Condensate Water From System

Refer to Fig. 6

1. Close the main valve controlling water supply to Deluge Valve. Also close valve A and open main drain valve B.
2. Open condensate drain valve H until all water has drained. Close valve H. **Note:** Be sure not to keep valve H open for an extended period of time because that will cause enough system air to bleed off thereby tripping the low air pressure switch causing an undesirable alarm condition.
3. Close main drain valve B. If system contains pressurized air, allow air pressure to come back up to specification. Open valve A first, and then open the main valve controlling the water supply to the Deluge Valve.

Maintenance Procedures - Model DDX Deluge Valve

Refer to Figs. 2, 5, & 6.

1. Mechanical sprinkler alarm (water motor—not shown) not operating:
This is most likely caused by a clogged screen in the strainer of the water motor. Proceed as follows: Remove plug from the strainer. Remove and clean the screen. Replace the screen and the plug, and then tighten securely (Ref. Bulletin 613).
2. Leakage out of the ball drip valve E (Fig. 6).
 - a. **Water leakage due to a water column above the Deluge Valve’s clapper:**
This condition can be caused by leakage past the system side of the Model DDX Deluge Valve’s seal assembly (#8, Fig. 5). Be sure that this surface is free of any type of debris. To eliminate leakage due to a water column, refer to the section in this bulletin marked “Draining Excess/Condensate Water From System”. If the problem continues proceed to the following section.
 - b. **Leakage, air or water from the ball drip valve, E (Fig. 6):**

If system air is leaking out the ball drip valve, the problem is either damage to the airside of the Model DDX Deluge Valve’s seal assembly (#8, Fig. 5), seat (#29, Fig. 5), mounting ring O-ring (#2, Fig. 5), or the upper seat O-ring (#23, Fig. 5). If supply water is leaking out the ball drip valve, the problem could be caused by damage to the Model DDX Deluge Valve’s seal assembly (#8, Fig. 5), seat (#29, Fig. 5), or lower seat O-ring (#24, Fig. 5). The following section provides instructions to correct both conditions:

- A. Shut down the valve controlling the water supply to the Deluge Valve and open the 2” main drain valve B (Fig. 6). Open the water column drain valve H (Fig. 6). Close the pushrod chamber supply valve A (Fig. 6) and open the Model B Manual Emergency Station, valve D (Fig. 6).
- B. Remove the Deluge Valve’s front (handhold) cover (#7, Fig. 5) and inspect the seat (#29, Fig. 5), clapper (#6, Fig. 5), and seal assembly (#8, Fig. 5) for damage.

If inspection indicates damage to the seal assembly (#8, Fig. 5), replace as follows:

Remove the bumpstop nuts (#10, Fig. 5) and remove the seal assembly (#8, Fig. 5). Install a new seal assembly (#8, Fig. 5) and thread the bumpstop nuts (#10, Fig. 5) onto the threaded stud of the seal assembly (#8, Fig. 5) and tighten finger tight plus ¼ to ½ turn.

If inspection indicates damage to the clapper (#6, Fig. 5) only, then the clapper sub-assembly can be removed as follows:

At the rear of the valve, disconnect the water column drain trim section starting with the elbow connector (#14, Fig. 2). Then remove the 1/4" globe valve (#25, Fig. 2), followed by the 3/4" x 1/4" reducing bushing (#9, Fig. 2). Remove the retaining ring (water column drain line side) from the clapper hinge pin (#30, Fig. 5) and push this pin through the handhold cover and remove the clapper subassembly. Replace the seal assembly (#8, Fig. 5) as described previously. Inspect the clapper (#6, Fig. 5) visually before reinstalling. Reinstall in the reverse order making sure the clapper spacers are in their proper position. If the seat (#29, Fig. 5) is damaged or it is suspected that the leakage is through the lower O-ring (#24, Fig. 5), the seat-clapper subassembly is easily removed as a unit as follows:

Using Reliable P/N 6881608000 Seat Wrench, remove the seat by unscrewing. This will loosen the seat-clapper-mounting ring subassembly. Reach into the valve and grasp the seat and remove it. Then remove the clapper-mounting ring subassembly from the valve. Visually examine all components of the seat and clapper-mounting ring sub-assembly replacing any component that appears damaged. New O-rings (#2, #23 & #24, Fig. 5) should always be used for reassembly.

Reassembly:

Clean the bore of the valve body. Lubricate the bore with O-ring grease. Lubricate and install the O-rings (#23 & #24, Fig. 5) onto the seat and O-ring (#2, Fig. 5) into the body (#1, Fig. 5). Insert the clapper-mounting ring sub-assembly into the handhold opening of the Deluge Valve. Align the mounting ring so that the Lever (#15, Fig. 5) is near the pushrod (#25, Fig. 5) and the mounting ring (#5, Fig. 5) "ears" are between the tabs of the valve body (#1, Fig. 5). Insert the seat (#29, Fig. 5) into the valve body (#1, Fig. 5) and through the clapper-mounting ring assembly. Start to tread the seat (#29, Fig. 5) into the body by hand, then tighten until the seat (#29, Fig. 5) with seat wrench 6881608000 until it bottoms out on the mounting ring (#5, Fig. 5). Verify that the seat-clapper-mounting ring subassembly is in the fully down position between the tabs of the body, and check to see that the lever (#15, Fig. 5) lines up with the push rod (#25, Fig. 5). Loosen and reassemble if necessary. Reassemble the handhold cover (#7, Fig. 5) and set up the Model DDX Deluge Valve as per the section "Resetting Model DDX Deluge Valve Systems."

3. Leakage out of the push rod chamber vent hole:

A small bleed hole is located on the underside of the push rod chamber (see Fig. 5). If there is air or water leakage coming out of this hole, do the following:

- a. Shut down the valve controlling water supply to the Deluge Valve. Relieve the inlet pressure by opening the main drain valve B (Fig. 6). Close the valve A (Fig. 6) that supplies water to the pushrod chamber, and open the Model B Manual Emergency Station, valve D (Fig. 6).
- b. Remove the trim at the unions nearest to the pushrod chamber cover (#3, Fig. 5)
- c. Take the push rod chamber cover (#3, Fig. 5) off by removing the six retaining screws (#26, Fig. 5).

CONDITION ONE (Water coming out of the bleed hole):

Water coming out of the bleed hole is caused by a leaking diaphragm (#18, Fig. 5). Visually inspect the pushrod chamber cover (#3, Fig. 5) and piston (#17, Fig. 5) to determine what could have damaged the diaphragm and correct. Install a new diaphragm.

NOTE: The diaphragm has two different surfaces; it is not bi-directional. It will fail if installed backwards!

Roll the diaphragm so that the smooth surface (the pressure side) conforms to the inside of the push rod chamber cover and reassemble the six retaining screws (#26, (Fig. 5) with an installation torque of 15 foot-pounds. Set up the Model DDX Deluge Valve as per the section "Resetting the Type D Double Interlock Praction System"

CONDITION TWO (System Air coming out of the bleed hole):

System air coming out of the bleed hole is caused by a defective O-ring assembled to the push rod guide (#11, Fig. 5). Remove the piston-push rod subassembly, push rod spring (#34, Fig. 5), and push rod guide (#11, Fig. 5). Verify by hand turning, that the push rod cannot be unscrewed from the piston. Replace all O-rings and the push rod guide (#11, #21 & #22, Fig. 5). The correct installation torque for the push rod guide is 35 inch-pounds.

CAUTION: Do not over-tighten the push rod guide. Reassemble the components that were initially removed. Re-install the diaphragm (#18, Fig. 5) if it appears to be in good shape, otherwise, replace it also.

NOTE: The diaphragm has two different surfaces, it is not bi-directional. It will fail if installed backwards!

Roll the diaphragm so that the smooth surface (the pressure side) conforms to the inside of the push rod chamber cover and reassemble the six retaining screws (#26, Fig. 5) with an installation torque of 15 foot-pounds. Set up the Model DDX Deluge Valve as per the section "Resetting the Type D Double Interlock PractionSystem."

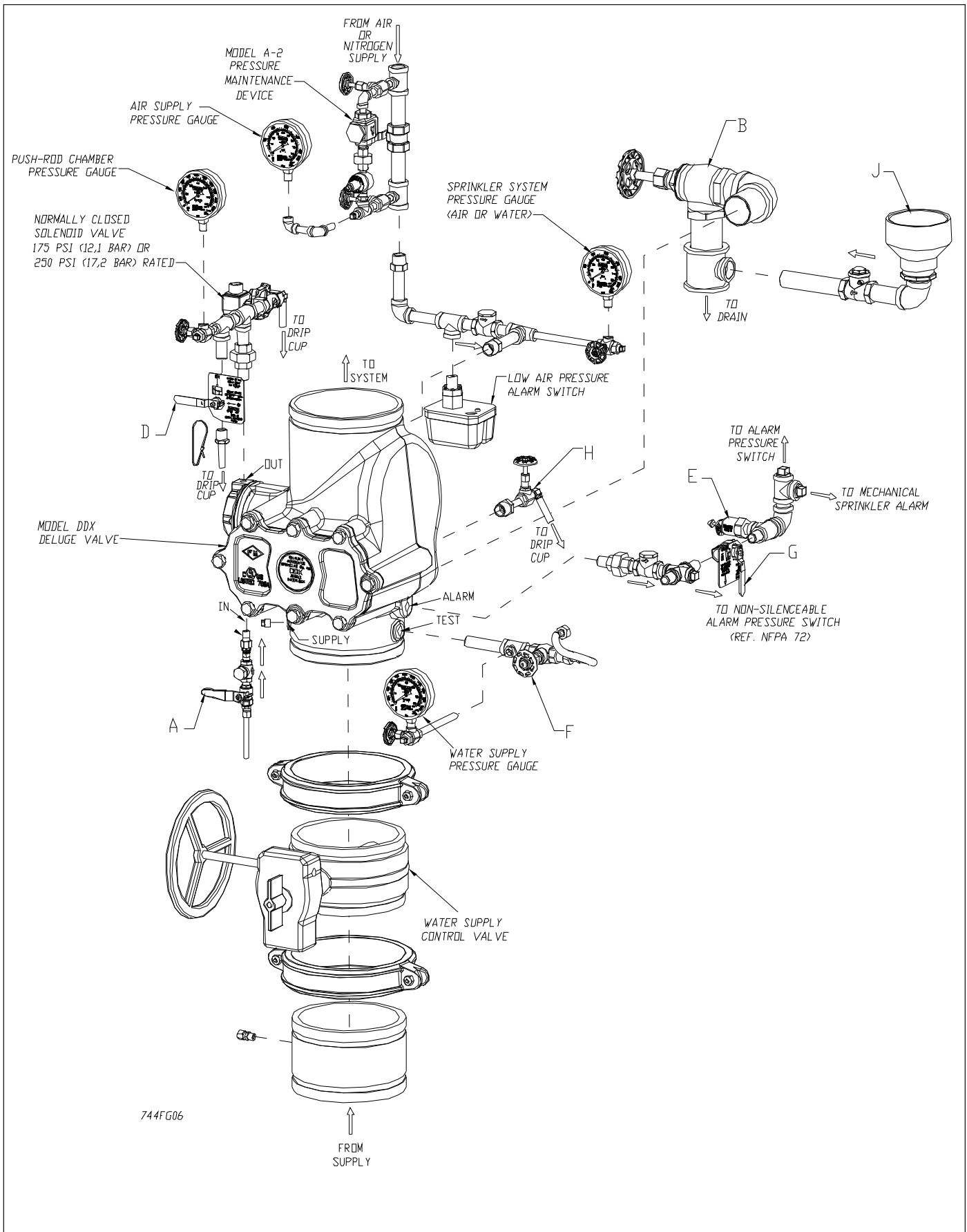

Fig. 6

Ordering Information:

Specify:

- **Valve Model & Size** — 8" (200 mm) Model DDX Deluge Valve (P/N 6103080001)
- **Trim** – the trim set is available in individual parts, in time-saving segmentally assembled kit forms, or fully assembled to the Model DDX Deluge Valve with or without a control valve.
- **Solenoid Valve** – 175 psi (12,1 bar) or 250 psi (17,2 bar) Rated. Explosion-Proof Solenoid Valve available upon request
- **Low Air Pressure Switch** – UL/FM Approved (System Sensor Model EPS10-2) or ULC Listed (System Sensor Model EPSA10-2).

		Trim Configurations	Trim Part Numbers
UL/FM Approved Pressure Switch	175 psi (12,1 bar) Rated Solenoid Valve	Fully Assembled to DDX Valve w/ Control Valve	6505080225
		Fully Assembled to DDX Valve w/o Control Valve	6505080226
		Segmentally Assembled (DDX Valve Sold Separately)	6503031441
		Individual Parts (DDX Valve Sold Separately)	6503031440
	250 psi (17,2 bar) Rated Solenoid Valve	Fully Assembled to DDX Valve w/ Control Valve	6505080245
		Fully Assembled to DDX Valve w/o Control Valve	6505080246
		Segmentally Assembled (DDX Valve Sold Separately)	6503031443
		Individual Parts (DDX Valve Sold Separately)	6503031442
ULC Approved Pressure Switch	175 psi (12,1 bar) Rated Solenoid Valve	Fully Assembled to DDX Valve w/ Control Valve	6505080255
		Fully Assembled to DDX Valve w/o Control Valve	6505080256
		Segmentally Assembled (DDX Valve Sold Separately)	6503031445
		Individual Parts (DDX Valve Sold Separately)	6503031444
	250 psi (17,2 bar) Rated Solenoid Valve	Fully Assembled to DDX Valve w/ Control Valve	6505080260
		Fully Assembled to DDX Valve w/o Control Valve	6505080261
		Segmentally Assembled (DDX Valve Sold Separately)	6503031447
		Individual Parts (DDX Valve Sold Separately)	6503031446

Note: For metric installations, a 2" NPT x R2. ISO 7/1 x Close Nipple (Reliable P/N 98543401) is sold separately as an adapter for the single drain outlet of the trims.

• **Additional equipment** (Refer to Fig. 7)

Component Part	Mfgr.	Description	Technical Bulletin
Water Supply Control Valve	Select	OS&Y, 8" (200 mm)	-
		Butterfly, 8" (200 mm)	-
Tamper Switch (Optional) for OS&Y Valve	D	Model OS&Y2	System Sensor A05-0196
Tamper Switch (Optional) for Butterfly Valve		Model P1BV2	System Sensor A05-0197
Deluge Valve	B	Model DDX 8" (200 mm)	Reliable 514/515
Double Interlock Trim Kit (Type D)	B	Refer to Parts in this Bulletin	Reliable 744
Waterflow Alarm/Low Air Pressure Switch	D	Model EPS10-2 (DPDT UL, FM)	System Sensor A05-0176
		Model EPSA10-2 (DPDT ULC)	
Mechanical Alarm (Optional)	B	Model C	Reliable 612/613
Releasing/Control Panel	C	Model PFC-4410-RC	Potter #5403550 Reliable 700
Batteries		12 VDC, 12 AMP Hours (90 Hours Backup) FM 12 VDC, 7 AMP Hours (60 Hours Backup)	
Optional Accessories		CA2Z (Class A Wiring Module for Initiating Circuits)	
		CAM (Class A Wiring Module for Indicating Circuits)	
		ARM-1/ARM-2 (Auxiliary Relay Module)	
Alarm Annunciator	A	Model SSM24-8 24 VDC/Polarized Bell	Reliable 700
		Model SSM24-10 24 VDC/Polarized Bell	
		Model MA24-D 24 VDC/Polarized Sounder	
		Model MASS24LO 24 VDC/Polarized Sounder Strobe	
Trouble Annunciator	A	Model SSM24-6 24 VDC/Polarized Bell	Reliable 700
		Model MA24-D 24 VDC/Polarized Sounder	
Manual Emergency Station (Elec.)	A	Model BNG-1 (SPDT) 1 & 2 Area Detection	Reliable 700
		Model BNG-1F (DPDT) Cross Zoned Detection	
Detection	Various	Smoke, Heat Detectors, etc.	Reliable 722
Sprinklers	B	Closed Type	Reliable 110, 117, 131, 136, etc.
Air Compressor	E	Tank Mounted	Gast H-10-0801
Nitrogen Regulating Device	B	Regulator with Optional Low Air Pressure Switch	Reliable 253

System Equipment Manufacturers

- | | |
|--|------------------------------|
| (A) Notifier | (D) System Sensor |
| (B) The Reliable Automatic Sprinkler Co. | (E) Gast Manufacturing Corp. |
| (C) Potter Electric Signal Company | |

TYPE D DOUBLE INTERLOCK PREACTION SYSTEM COMPONENTS

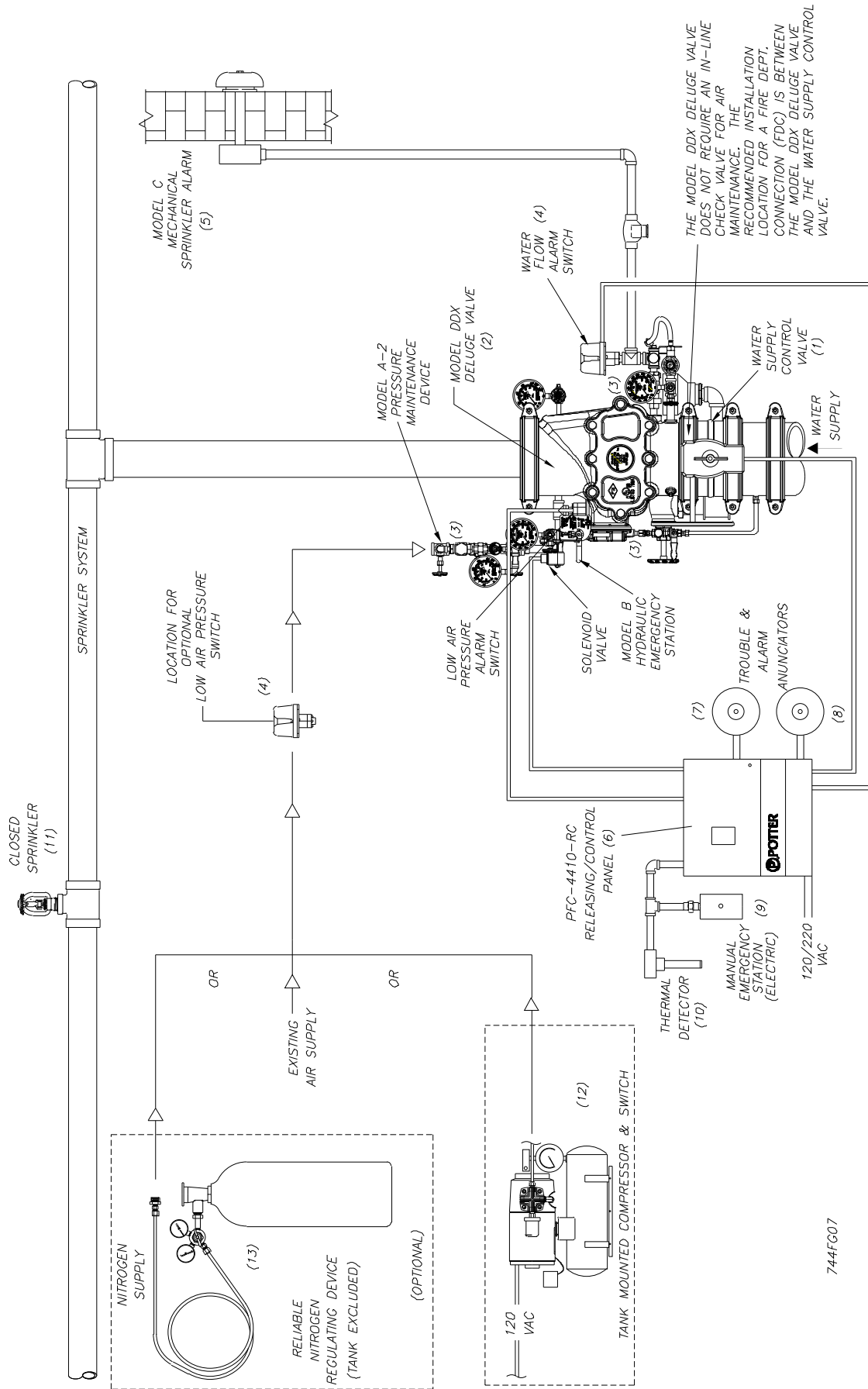

Fig. 7

Installation Dimensions in Inches (mm)

A	B	C	*D	E	F	G	H	J	K	L	M	N	P	Q	R
7¼ (184)	9 (229)	11¼ (285)	19¾ (492)	15½ (394)	31 (787)	9 (229)	10 (254)	5½ (140)	8½ (216)	15 (381)	2¾ (70)	4½ (114)	9 (229)	13 (330)	13 (330)

* Total takeout dimension for fully assembled to Model DDX Valve w/ Control Valve Configuration: 30¼ [768]

TRIM SHOWN FULLY ASSEMBLED WITHOUT CONTROL VALVE

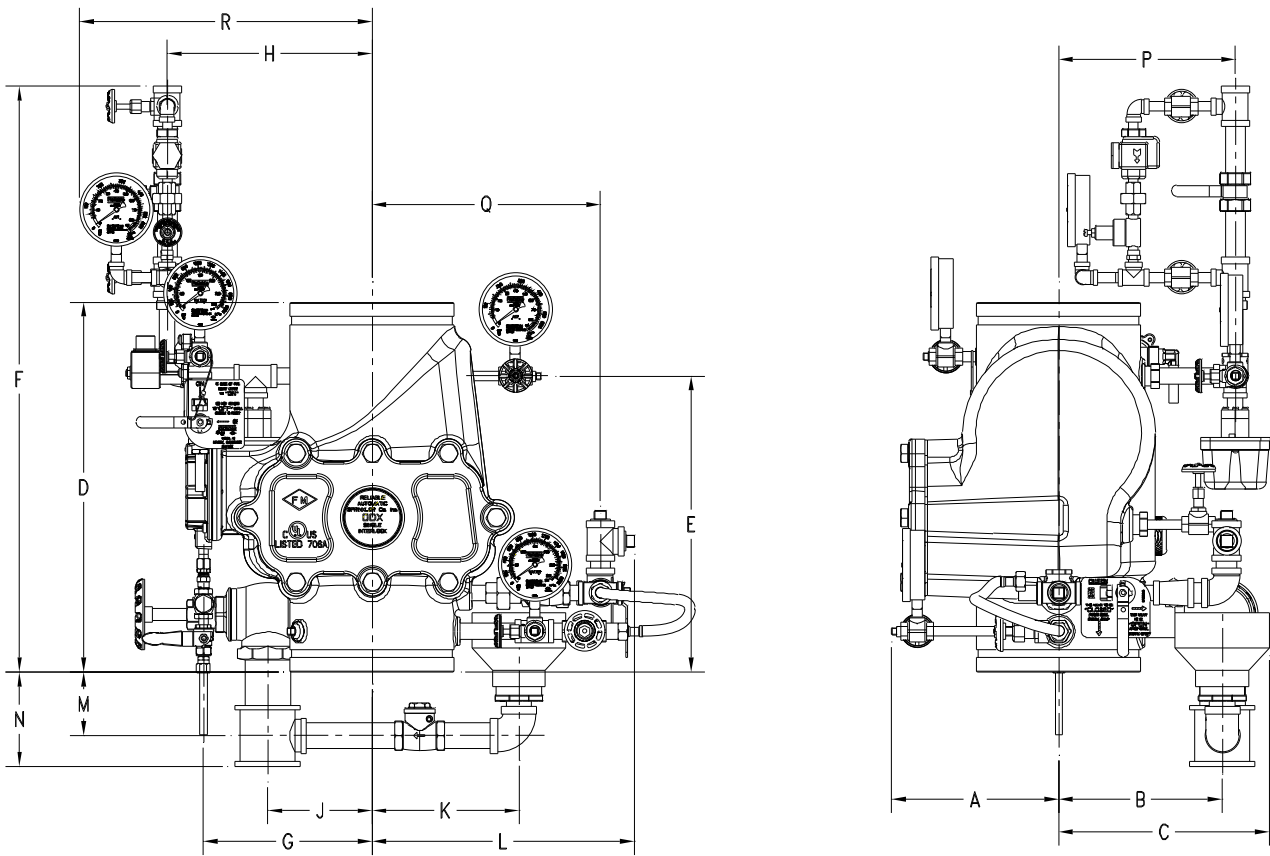

744BKP

SOLENOID VALVE INSPECTIONS, TESTS AND MAINTENANCE

WARNING: THE OWNER IS RESPONSIBLE FOR MAINTAINING THE FIRE PROTECTION SYSTEM IN PROPER OPERATING CONDITION. ANY SYSTEM MAINTENANCE OR TESTING THAT INVOLVES PLACING A CONTROL VALVE OR DETECTION SYSTEM OUT OF SERVICE MAY ELIMINATE THE FIRE PROTECTION OF THAT SYSTEM. PRIOR TO PROCEEDING, NOTIFY ALL AUTHORITIES HAVING JURISDICTION. CONSIDERATION SHOULD BE GIVEN TO EMPLOYMENT OF A FIRE PATROL IN THE AFFECTED AREA.

WARNING: PRIOR TO OPERATING THE SOLENOID VALVE, BE SURE TO CLOSE THE SYSTEM CONTROL VALVE TO AVOID UNINTENTIONAL OPERATION OF THE DELUGE VALVE

1. Inspections: It is imperative that the system be inspected and tested in accordance with NFPA 25 on a regular basis. The frequency of the inspections may vary due to contaminated water supplies, corrosive water supplies, or corrosive atmospheres. In addition, the alarm devices, detection systems, or other connected trim may require a more frequent schedule. Refer to the system description and applicable codes for minimum requirements.
2. The valve must be operated at least monthly. The valve must open and close freely. When open, the water flow must be clear and clean at the proper flow rate. When closed, a total water shut-off must be observed.
3. The valve must be inspected at least monthly for cracks, corrosion, leakage, etc., and cleaned, repaired, or replaced, or replaced as necessary.
4. At least annually, the valve diaphragms and seats must be inspected and if necessary, repaired or replaced.

WARNING: CLOSE SYSTEM CONTROL VALVE, TURN OFF POWER SUPPLY, AND DEPRESSURIZE VALVE BEFORE DISASSEMBLING VALVE. IT IS NOT NECESSARY TO REMOVE THE VALVE FROM THE PIPE LINE TO MAKE INSPECTIONS.

5. When lubricating valve components, use high grade silicone grease (Dow Corning® 111 Compound Lubricant or equal).
6. When reassembling, tighten parts to torque values indicated in the manufacturer's maintenance instructions (packed with valve).
7. After maintenance is completed, operate the valve a few times to be sure of proper operation. A metallic "click" signifies the solenoid is operating.
8. It is recommended that the valve be replaced at seven-year intervals. Shorter intervals may be required if the valve is subject to corrosive water supplies or atmospheres.
9. All service must be performed by qualified personnel. Upon completion of inspections or replacement of the valve, the entire system must be checked for proper operation. See appropriate system description and testing instructions for additional information.

Reliable...For Complete Protection

Reliable offers a wide selection of sprinkler components. Following are some of the many precision-made Reliable products that guard life and property from fire around the clock.

- Automatic sprinklers
- Flush automatic sprinklers
- Recessed automatic sprinklers
- Concealed automatic sprinklers
- Adjustable automatic sprinklers
- Dry automatic sprinklers
- Intermediate level sprinklers
- Open sprinklers
- Spray nozzles
- Alarm valves
- Retarding chambers
- Dry pipe valves
- Accelerators for dry pipe valves
- Mechanical sprinkler alarms
- Electrical sprinkler alarm switches
- Water flow detectors
- Deluge valves
- Detector check valves
- Check valves
- Electrical system
- Sprinkler emergency cabinets
- Sprinkler wrenches
- Sprinkler escutcheons and guards
- Inspectors test connections
- Sight drains
- Ball drips and drum drips
- Control valve seals
- Air maintenance devices
- Air compressors
- Pressure gauges/identification signs
- Fire department connection

The equipment presented in this bulletin is to be installed in accordance with the latest published Standards of the National Fire Protection Association, Factory Mutual Research Corporation, or other similar organizations and also with the provisions of governmental codes or ordinances whenever applicable. Products manufactured and distributed by Reliable have been protecting life and property for over 80 years, and are installed and serviced by the most highly qualified and reputable sprinkler contractors located throughout the United States, Canada and foreign countries.

Manufactured by

Reliable[®]

The Reliable Automatic Sprinkler Co., Inc.
(800) 431-1588 Sales Offices
(800) 848-6051 Sales Fax
(914) 829-2042 Corporate Offices
www.reliablesprinkler.com Internet Address



Revision lines indicate updated or new data.
EG. Printed in U.S.A 03/09 P/N 999970356