



# Model F3 Dry Sprinklers

## Features

1. The Model F3 Sprinkler utilizes Belleville Spring Closure Technology
2. Styles available for Model F3 Dry Sprinklers:
  - Pendent
  - Recessed Pendent
  - Concealed
  - Horizontal Sidewall
  - Recessed Horizontal Sidewall
3. 1½" (38mm) escutcheon adjustment on pendent sprinkler.
4. ½" (13mm) escutcheon adjustment on recessed sprinkler with push-on/thread-off FP Model escutcheon ring.
5. 3/8" (9.5mm) cover plate adjustment on concealed sprinkler with push-on/ thread-off CCP cover.
6. Attractive appearance. Employs 5mm frangible glass bulb and galvanized nipple.
7. Lengths available to accommodate installation dimensions from 2" - to - 48" (51mm - to - 1219mm), in ¼" (6mm) increments.
8. Available in a variety of plated and painted finishes.
9. Polyester Coated Corrosion Resistant Sprinklers.

U.S. Patent Numbers 5,775,431 and 5,967,240.

## Approvals

1. Listed by Underwriters Laboratories Inc. and UL Certified for Canada (cULus).

Style	Response	Sprinkler System Type	Hazard
Pendent Recessed Pendent CCP Concealed (R5314) Horizontal Sidewall Recessed Horizontal Sidewall (R5334)	Standard	Wet Pipe Dry Pipe All Preaction	Light Ordinary

2. Certified by FM Approvals

Style	Response	Sprinkler System Type	Hazard
Pendent Recessed Pendent CCP Concealed (R5314)	Standard	Wet Pipe Dry Pipe All Preaction	Light Ordinary, Groups 1&2
Horizontal Sidewall Recessed Horizontal Sidewall (R5334)	Standard	Wet Pipe Dry Pipe All Preaction	Light

3. NYC MEA 258-93-E
4. LPCB Approved, CE listed 0832-CPD-2006

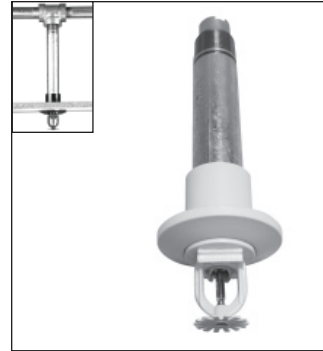

Pendent



Pendent / HB



Recessed FP Pendent



Concealed



Horizontal Sidewall



Horizontal FP Sidewall



Horizontal Sidewall / HB

# Model F3 Dry Pendant Sprinkler

**"A" Dim.** 2" to 48" (51mm to 1219mm) in 1/4" (6mm) increments

## Finishes<sup>(1)</sup>

Sprinkler	Escutcheon
Bronze	Brass
Chrome Plated	Chrome Plated
White Polyester <sup>(4)</sup>	White
Lead Plated <sup>(2)</sup>	
Wax Coated <sup>(2)(3)</sup>	
Wax Over Lead <sup>(2)(3)</sup>	

<sup>(1)</sup> Other finishes and colors are available on special order. Consult factory for details.

<sup>(2)</sup> 155°F (68°C) to 200°F (93°C) rating only.

<sup>(3)</sup> 212°F (100°C) brown wax may be used on 286°F (141°C) sprinklers when maximum ceiling temperatures do not exceed 150°F (66°C).

<sup>(4)</sup> cULus Listed as a Corrosion Resistant sprinkler in standard Black or White.

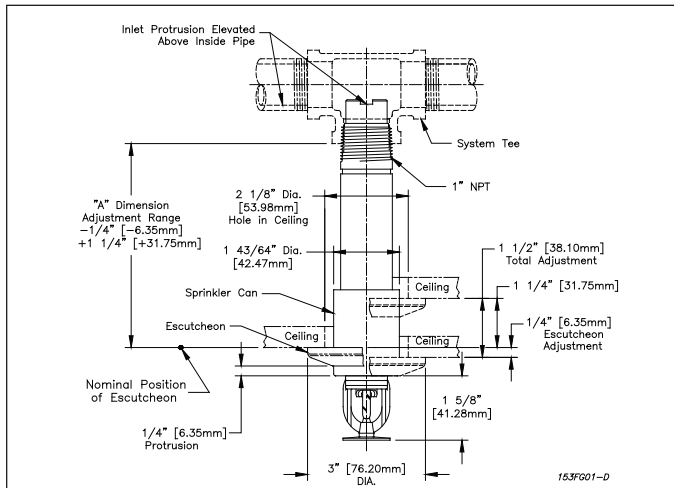

Fig. 1

**Note:** The sprinkler can protrudes 1/4" when escutcheon is in nominal position. Escutcheon adjustment provides -1/4" (-6mm) to +1/4" (+32mm) "A" dimension adjustment range.

**Sprinkler Guard:** Model C-2

**Sprinkler Installation Wrench:** Model G3 Sprinkler Wrench

**Sprinkler Identification Number (SIN):** R5314

# Model F3 Dry Pendant FP Recessed Sprinkler

**"A" Dim.** 3 1/2" to 48" (89mm to 1219mm) in 1/4" (6mm) increments

## Finishes<sup>(1)</sup>

Sprinkler	Escutcheon
Bronze	Brass
Chrome Plated	Chrome Plated
White Polyester <sup>(2)</sup>	White

<sup>(1)</sup> Other finishes and colors are available on special order.

Consult factory for details. Cup remains unfinished.

Only the escutcheon will contain desired finish.

<sup>(2)</sup> cULus Listed as a Corrosion Resistant sprinkler in standard Black or White.

## Standard Temperature Ratings

Classification	Sprinkler Temperature Rating	Max. Ambient Temp.	Bulb Color
Ordinary	135°F (57°C)	100°F (38°C)	Orange
Ordinary	155°F (68°C)	150°F (66°C)	Red
Intermediate <sup>(2)</sup>	175°F (79°C)	150°F (66°C)	Yellow
Intermediate	200°F (93°C)	150°F (66°C)	Green
High <sup>(1)</sup>	286°F (141°C)	225°F (107°C)	Blue

Sprinkler cup and FP Escutcheon fabricated of steel and recommended for interior applications.

<sup>(1)</sup> **Listed and Certified Only by LPCB and cULus.**

<sup>(2)</sup> **Listed and Certified Only by cULus.**

**Sprinkler Installation Wrench:** Model G3 R/C Sprinkler Wrench

**Sprinkler Identification Number (SIN):** R5314

## Standard Temperature Ratings

Classification	Sprinkler Temperature Rating	Max. Ambient Temp.	Bulb Color
Ordinary	135°F (57°C)	100°F (38°C)	Orange
Ordinary	155°F (68°C)	100°F (38°C)	Red
Intermediate <sup>(1)</sup>	175°F (79°C)	150°F (66°C)	Yellow
Intermediate	200°F (93°C)	150°F (66°C)	Green
High	286°F (141°C)	225°F (107°C)	Blue

Sprinkler can and escutcheon fabricated of brass for better weather resistance in exterior applications.

<sup>(1)</sup> **Listed and Certified only by cULus.**

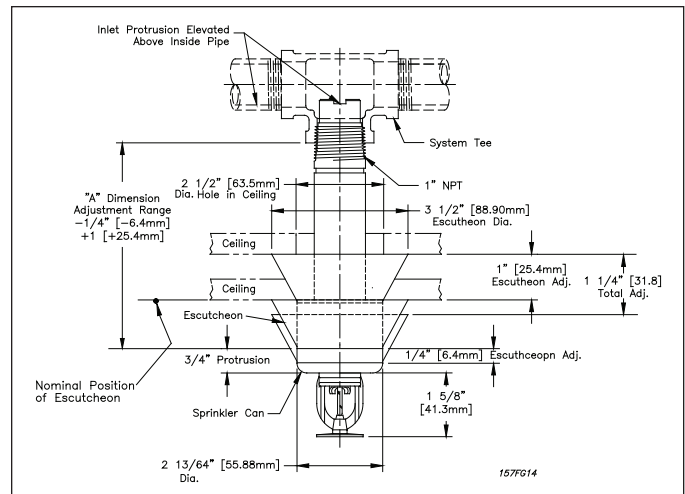

Fig. 2

**Note:** The sprinkler can protrudes 3/4" when escutcheon is in nominal position. Escutcheon adjustment provides -1/4" (-6mm) to +1" (+25mm) "A" dimension adjustment range.

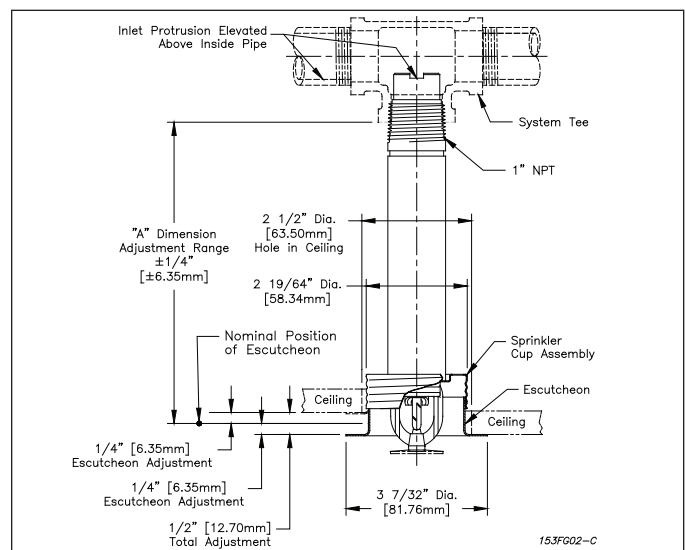

Fig. 3

**Note:** Do not install the Model F3 Dry Pendant Recessed Sprinkler in ceilings which have positive pressure in space above.

## Model F3 Dry Pendent Concealed Sprinkler

"A" Dim. 3 1/2" to 48" (89mm to 1219mm) in 1/4" (6mm) increments

### CCP Cover Plate <sup>(1)</sup> Finishes <sup>(2)</sup>

Standard Finishes	Special Application Finishes
Chrome Plated	Bright Brass Plated
White	Black Plated
	Black Paint
	Off White
	Satin Chrome

<sup>(1)</sup> Utilizes the 1/2" cover plate with 3/8" total adjustment.

<sup>(2)</sup> Other finishes and colors are available on special order.

Consult factory for details.

### Standard Temperature Ratings

Classification	Sprinkler Temperature Rating	Cover Plate Temp. Rating	Max. Ambient Temp.
Ordinary	135°F (57°C)	135°F (57°C)	100°F (38°C)
Ordinary	155°F (68°C)	135°F (57°C)	100°F (38°C)
Intermediate <sup>(1)</sup>	175°F (79°C)	165°F (74°C)	150°F (66°C)
Intermediate	200°F (93°C)	165°F (74°C)	150°F (66°C)
High <sup>(1)</sup>	286°F (141°C)	165°F (74°C)	150°F (66°C)

Sprinkler cup fabricated of steel and CCP Cover Plate fabricated of brass and recommended for interior applications.

<sup>(1)</sup> Listed and Certified only by cULus.

### Sprinkler Installation Wrench: Model G3 R/C Sprinkler Wrench

### Sprinkler Identification Number (SIN): R5314

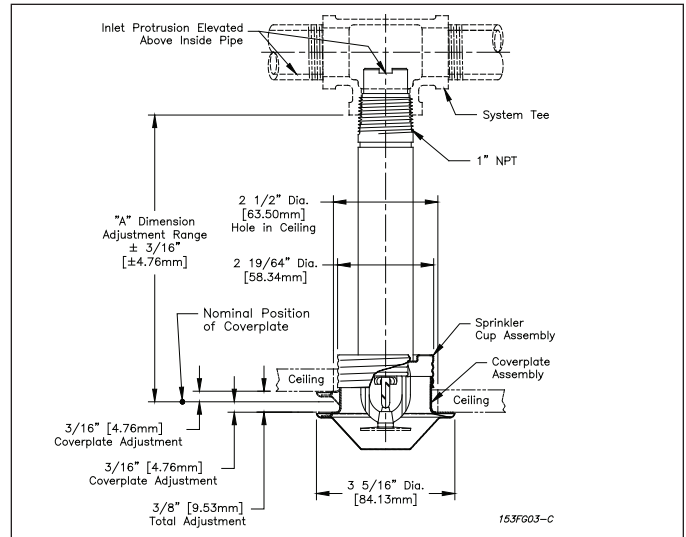

Fig. 4

**Note:** Do not install the Model F3 CCP Pendent Concealed Sprinkler in ceilings which have positive pressure in the space above.

## Model F3 Dry Horizontal Sidewall Sprinkler

"A" Dim. 2" to 48" (51mm to 1219mm) in 1/4" (6mm) increments

### Finishes <sup>(1)</sup>

Sprinkler	Escutcheon
Bronze	Brass
Chrome Plated	Chrome Plated
White Polyester <sup>(4)</sup>	White
Lead Plated <sup>(2)</sup>	
Wax Coated <sup>(2)(3)</sup>	
Wax Over Lead <sup>(2)(3)</sup>	

<sup>(1)</sup> Other finishes and colors are available on special order.

Consult factory for details.

<sup>(2)</sup> 155°F (68°C) to 200°F (93°C) rating only.

<sup>(3)</sup> 212°F (100°C) brown wax may be used on 286°F (141°C) sprinklers when maximum ceiling temperatures do not exceed 150°F (66°C).

<sup>(4)</sup> cULus Listed as a Corrosion Resistant sprinkler in standard Black or White.

### Standard Temperature Ratings

Classification	Sprinkler Temperature Rating	Max. Ambient Temp.	Bulb Color
Ordinary	135°F (57°C)	100°F (38°C)	Orange
Ordinary	155°F (68°C)	100°F (38°C)	Red
Intermediate <sup>(1)</sup>	175°F (79°C)	150°F (66°C)	Yellow
Intermediate	200°F (93°C)	150°F (66°C)	Green
High	286°F (141°C)	225°F (107°C)	Blue

Sprinkler can and escutcheon fabricated of brass for better weather resistance in exterior applications.

<sup>(1)</sup>Listed and Certified only by cULus.

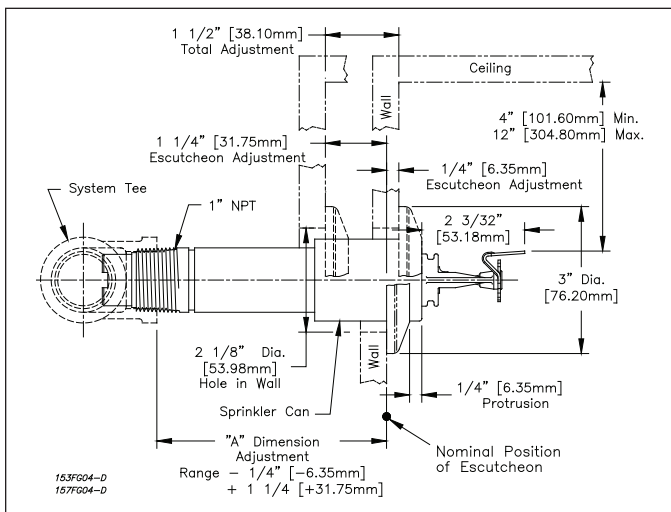

Fig. 5

**Note:** The sprinkler can protrudes 1/4" when escutcheon is in nominal position. Escutcheon adjustment provides - 1/4" (-6mm) to + 1 1/4" (+32mm) "A" dimension adjustment range.

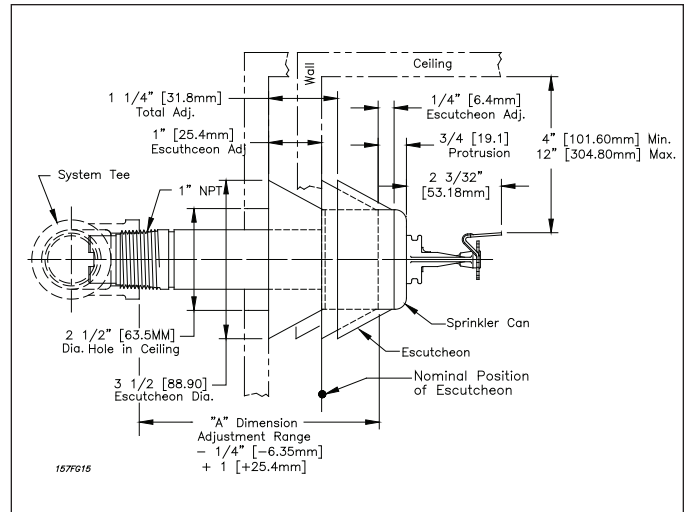

Fig. 6

**Note:** The sprinkler can protrudes 3/4" when escutcheon is in nominal position. Escutcheon adjustment provides - 1/4" (-6mm) to + 1" (+25mm) "A" dimension adjustment range.

### Sprinkler Installation Wrench: Model G3 Sprinkler Wrench

### Sprinkler Identification Number (SIN): R5334

## Model F3 Horizontal FP Recessed Sidewall Sprinkler

"A" Dim.	3 1/2" to 48" (89mm to 1219mm) in 1/4" (6mm) increments
----------	---

### Finishes <sup>(1)</sup>

Sprinkler	Escutcheon
Bronze	Brass
Chrome Plated	Chrome Plated
White Polyester <sup>(2)</sup>	White

<sup>(1)</sup> Other finishes and colors are available on special order.

Consult factory for details.

<sup>(2)</sup> cULus Listed as a Corrosion Resistant sprinkler in standard Black or White.

Sprinkler's can and FP Escutcheon are fabricated of steel and recommended for interior applications.

### Standard Temperature Ratings

Classification	Sprinkler Temperature Rating	Max. Ambient Temp.	Bulb Color
Ordinary	135°F (57°C)	100°F (38°C)	Orange
Ordinary	155°F (68°C)	100°F (38°C)	Red
Intermediate <sup>(1)</sup>	175°F (79°C)	150°F (66°C)	Yellow
Intermediate	200°F (93°C)	150°F (66°C)	Green
High <sup>(1)</sup>	286°F (141°C)	225°F (107°C)	Blue

<sup>(1)</sup>Listed and Certified Only by LPCB or cULus.

**Sprinkler Installation Wrench:** Model G3 R/C Sprinkler Wrench  
**Sprinkler Identification Number (SIN):** R5334

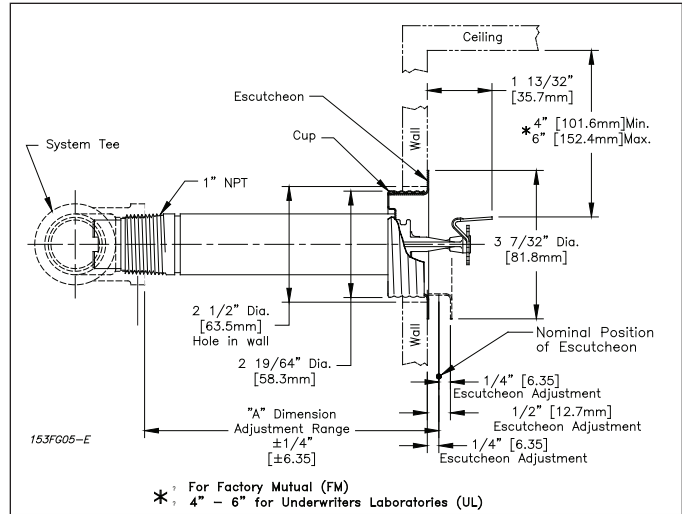

Fig. 7

**Note:** Do not install the Model F3 Dry Horizontal Recessed Sidewall Sprinkler in walls which have positive pressure in their side space.

- Recessed Horizontal Sidewall sprinklers are listed by cULus for installation of min. 4" (100mm) - to - max. 6" (150mm) below ceiling, and FM approved for installation of min. 4" (100mm) - to - max. 12" (306mm).

## Technical Data

Orifice Size: 1/2" (15mm)

Thread size: 1" NPT per ANSI B2.1

Working Pressure: 175 psi (12 bar)

Nominal K Factor - US / (Metric): 5.6 / (80)

## Product Description

Reliable Model F3 Dry Sprinklers are standard response sprinklers utilizing a durable 5mm frangible glass bulb. Model F3 Dry Sprinklers are intended for use in dry and pre-action systems and in areas subjected to freezing temperatures, such as freezers and unheated portions inside and outside buildings.

Environments wherein dry sprinklers are employed can be corrosive. For this reason, Model F3 Sprinklers have a special wax fillet placed in the gap between the cup that supports the bulb and the wrenching boss. This wax will not interfere with the operation of the sprinkler, and it prevents contaminants from entering the internal portion of the drop nipple. The wax must not be removed.

## Operation

The glass bulb consists of an accurately controlled amount of special fluid hermetically sealed inside a precisely manufactured glass capsule. When the temperature increases sufficiently due to a fire, the bulb shatters allowing operating parts to clear the waterway. This enables the inlet seal to release air or water and subsequently, cause water flow over the deflector in a uniform spray pattern, controlling or extinguishing the fire.

## Ordering Information

Specify:

1. Sprinkler Type (select one):
  - (a) Model F3 Dry Pendent
  - (b) Model F3 Dry Pendent/HB
  - (c) Model F3 Dry Recessed Pendent
  - (d) Model F3 Dry Concealed Pendent
  - (e) Model F3 Dry Horizontal sidewall
  - (f) Model F3 Dry Horizontal sidewall/HB
  - (g) Model F3 Dry Recessed Horizontal Sidewall
2. Sprinkler Temperature Rating.
3. Sprinkler Finish.
4. Cover Plate/FP Escutcheon Finish.
5. Length: "A" Dimension (face of tee to face of ceiling or wall) in 1/4" (6.4mm) increments.
6. Model F3 Dry Pendent (a) is available without sprinkler can and escutcheon.

**Note:**

1. The "A" dimension is based on a nominally gauged pipe thread "make-up" of .600" (15mm) per ANSI B2.1 [7 1/2 threads approximately].
2. All platings and paintings are decorative and intended for interior use.
3. Acceptable appearance in conditions such as parking garages is generally provided with bronze sprinkler, brass cup and escutcheon for the Model F3 Pendent only.

## General Installation Instructions

Model F3 dry sprinklers must be installed only in standard (ANSI B 16.3 class 150 and ANSI B 16.4 class 125) pipe tees in the horizontal position, even at branch line ends. They should not be installed into elbows or pipe couplings located on drop nipples to the sprinklers. For these and other fittings including CPVC, the dry sprinkler should be installed into a fitting to allow protrusion into the fitting in accordance with the diagrams. The "A" dimension of the dry sprinkler, which extends into the freezers or a freezing zone from wet pipe systems, should be selected to provide, as a minimum, the specified lengths in inches shown in Fig. 8.

### Caution:

Do not install Model F3 Dry sprinklers into CPVC adapter fittings or tees that have an internal obstruction. This will damage the sprinkler and /or the fitting. Refer to Fig. 9

During installation, the following steps must be followed:

1. Cut the specified size hole (see illustrations) for the sprinkler in the ceiling or wall directly in line with the tee.
2. Apply pipe joint compound to the 1" (25mm) pipe threads and install sprinkler using the Model G3 or G3 R/C Sprinkler Wrench as specified.
3. Install the Model FP push-on / thread-off escutcheon or CCP cover plate if required.

**Note:** Installation of the Model F3 Sprinklers is not recommended in copper pipe systems, as this may reduce the life expectancy of the sprinklers.

## Model F3 Concealed and Recessed Installation Instructions

- The Model G3 R/C Wrench (Fig. 10) is designed to locate on the wrenching pads of the Recessed sprinkler while centering in the cup. A standard ½" drive ratchet may be used to drive this wrench. Figures 11 and 12 show sequentially the insertion of the wrench. First, the wrench, with its jaws above the sprinkler deflector, is moved laterally until centered with the cup. Then raise the wrench inside the cup until its jaws engage the sprinkler's square wrenching pads (Fig. 12). To remove the wrench, follow this procedure in reverse order. Care should be taken to avoid striking the deflector with the wrench.
- Model G3 Wrench (Fig. 13) is used for installation of Pendant and Horizontal sidewall sprinklers.
- Glass bulb sprinklers have orange bulb protectors to minimize bulb damage during shipping, handling and installation. REMOVE THIS PROTECTION AT THE TIME THE SPRINKLER SYSTEM IS PLACED IN SERVICE FOR FIRE PROTECTION. Removal of the protectors before this time may leave the bulb vulnerable to damage. RASCO wrenches are designed to install sprinklers when covers are in place. REMOVE PROTECTORS BY UNDOING THE CLASP BY HAND. DO NOT USE TOOLS TO REMOVE THE PROTECTORS.

## Maintenance

The Model F3 Dry Sprinklers should be inspected quarterly and the sprinkler system maintained in accordance with NFPA 25. Do not remove the factory applied thermally sensitive wax fillet between the bulb supporting cup and the wrenching boss. Do not replace this wax with a substitute substance. An Alternate substance may interfere with proper operation of the sprinkler. Do not clean sprinklers with soap and water, ammonia or any other cleaning fluids. Remove dust by using a soft brush or gently vacuuming. Remove any sprinkler which has been painted (other than factory applied) or damaged in any way. A stock of spare sprinklers should be maintained to allow quick replacement of damaged or operated sprinklers. Prior to installation, sprinklers should be maintained in the original cartons and packaging until used to minimize the potential for damage to sprinklers that would cause improper operation or non-operation.



RECOMMENDED EXPOSED MINIMUM BARREL LENGTH BASED ON AMBIENT TEMPERATURE IN THE PROTECTED AREA  
(STANDARD DRY PENDENT SPRINKLER SHOWN)

AMBIENT TEMPERATURE OF PROTECTED AREA* AT THE DISCHARGE END OF THE SPRINKLER	EXPOSED BARREL AMBIENT TEMPERATURE		
	40°F/4°C	50°F/10°C	60°F/16°C
	EXPOSED MINIMUM BARREL LENGTH** (FACE OF TEE TO TOP OF CEILING)		
	IN. (MM)	IN. (MM)	IN. (MM)
40°F (4°C)	0	0	0
30°F (-1°C)	0	0	0
20°F (-7°C)	4 (101)	0	0
10°F (-12°C)	8 (203)	1 (25.1)	0
0°F (-18°C)	12 (305)	3 (75)	0
-10°F (-23°C)	14 (356)	4 (101)	1 (25.1)
-20°F (-29°C)	14 (356)	6 (152)	3 (75)
-30°F (-34°C)	16 (406)	8 (203)	4 (101)
-40°F (-40°C)	18 (457)	8 (203)	4 (101)
-50°F (-46°C)	20 (508)	10 (254)	6 (152)
-60°F (-51°C)	20 (508)	10 (254)	6 (152)

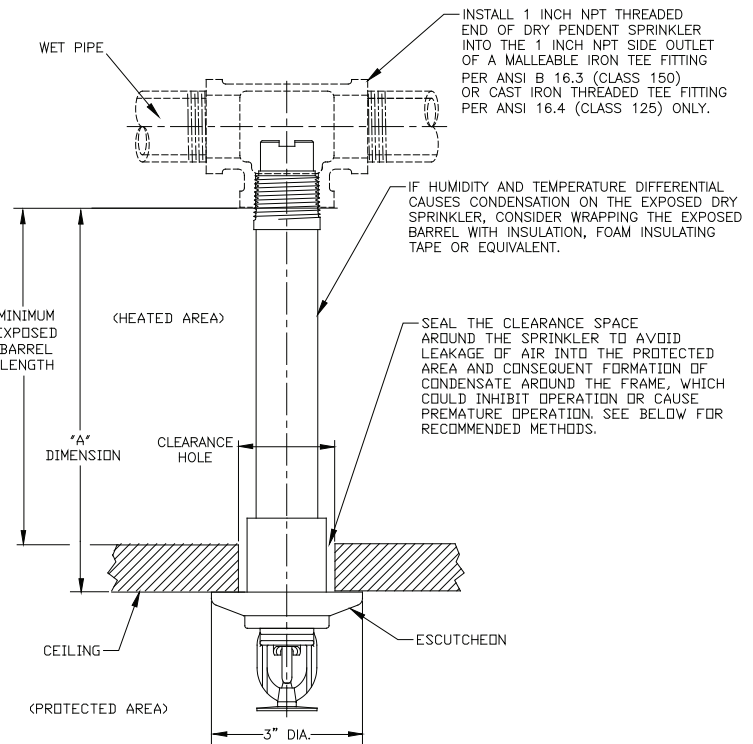

\* THE PROTECTED AREA REFERS TO THE AREA BELOW THE CEILING. THE AMBIENT TEMPERATURE IS THE TEMPERATURE AT THE DISCHARGE END OF THE SPRINKLER. FOR PROTECTED AREA TEMPERATURES THAT OCCUR BETWEEN THE VALUES LISTED, USE THE NEXT COOLER TEMPERATURE.

\*\*THE MIN. REQUIRED BARREL LENGTH IS NOT THE SAME AS THE 'A' DIMENSION. NOTE: EXPOSED MINIMUM BARREL LENGTHS ARE INCLUSIVE UP TO 30MPH WIND VELOCITIES IN THE PROTECTED AREA.

\*RECOMMENDED EXPOSED MINIMUM BARREL LENGTHS ALSO APPLY TO HORIZONTAL SIDEWALL DRY SPRINKLERS\*

RECOMMENDED DRY SPRINKLER SEAL ARRANGEMENTS  
(STANDARD DRY PENDENT SPRINKLER SHOWN)

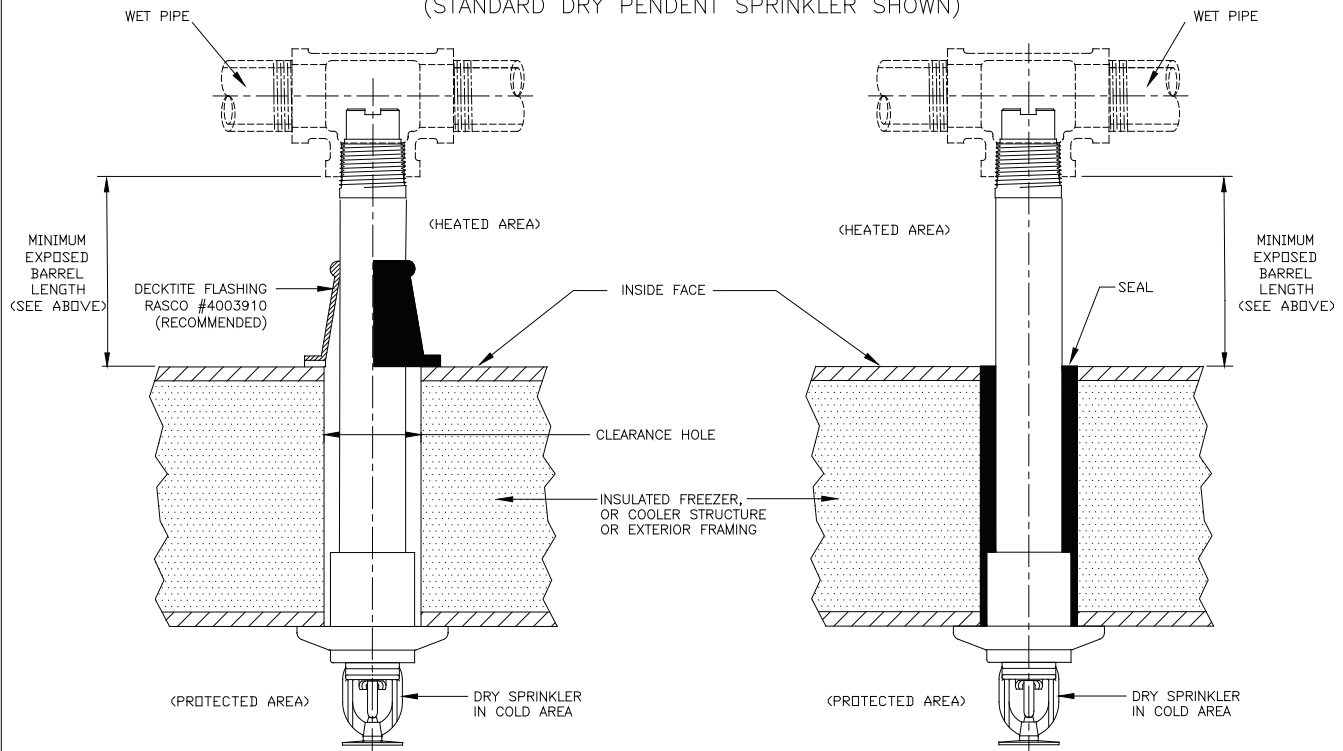

1577006A

Fig. 8

**\*CAUTION\***

DO NOT INSTALL MODEL F3, MODEL F3QR OR MODEL DH56 HSW DRY SPRINKLERS INTO CPVC ADAPTER FITTINGS OR TEES THAT HAVE AN INTERNAL OBSTRUCTION. THIS WILL DAMAGE THE SPRINKLER AND/OR THE FITTING. CPVC ADAPTER FITTINGS AND TEES WITH INTERNAL OBSTRUCTIONS ARE ALSO COMMONLY FOUND DURING THE RETROFITTING PROCESS OF RELIABLE'S OLDER MODEL G3 DRY SPRINKLERS.

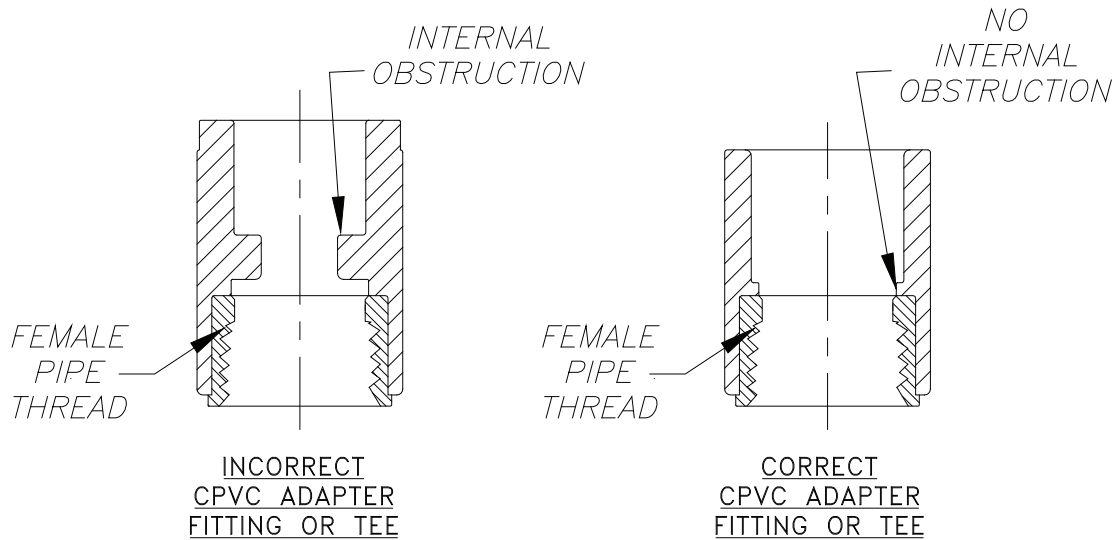

RELIABLE MANUFACTURES A FULL-LINE OF MODEL F3-PL, MODEL F3QR-PL, AND MODEL DH56 HSW-PL DRY SPRINKLERS THAT HAVE A SHORTER INLET FOR THESE APPLICATIONS.

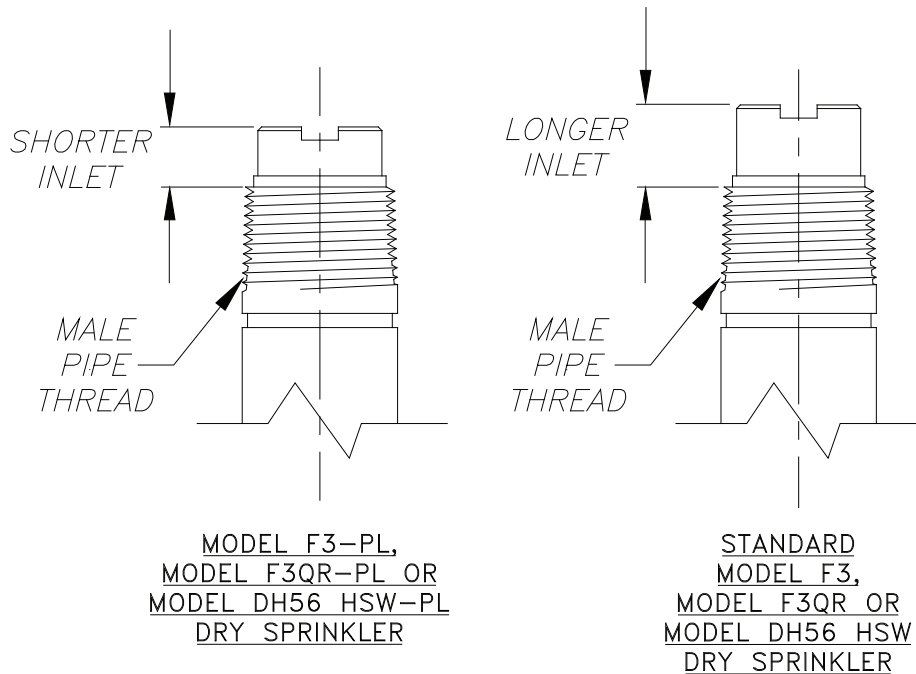

BE SURE TO ORDER THE CORRECT SPRINKLERS FOR YOUR APPLICATION

016fg08

Fig. 9



Fig. 10 - G3 R/C Wrench

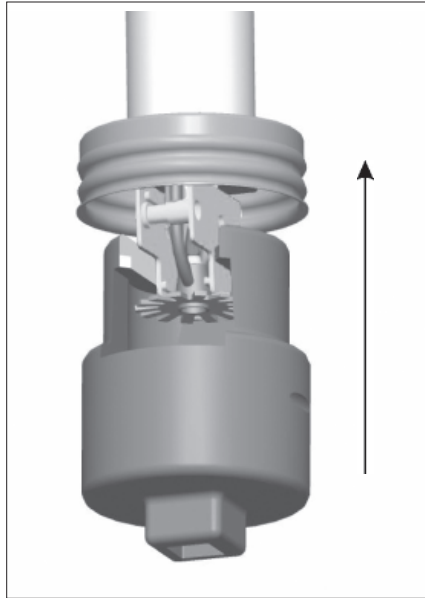

Fig. 11 - G3 R/C Wrench

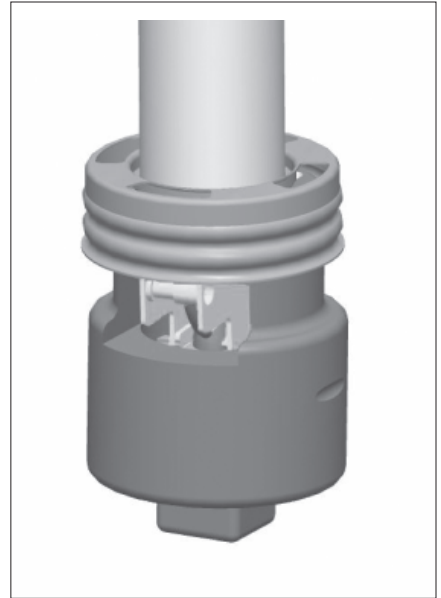

Fig. 12 - G3 R/C Wrench

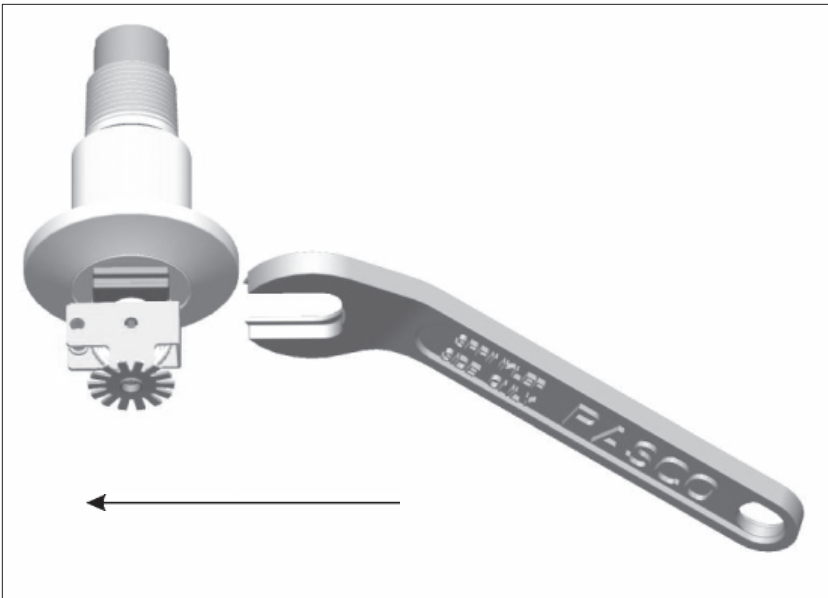

Fig. 13 - G3 Wrench

The equipment presented in this bulletin is to be installed in accordance with the latest published Standards of the National Fire Protection Association, Factory Mutual Research Corporation, or other similar organizations and also with the provisions of governmental codes or ordinances whenever applicable.

Products manufactured and distributed by Reliable have been protecting life and property for over 90 years, and are installed and serviced by the most highly qualified and reputable sprinkler contractors located throughout the United States, Canada and foreign countries.

Manufactured by



**The Reliable Automatic Sprinkler Co., Inc.**

(800) 431-1588

(800) 848-6051

(914) 829-2042

www.reliablesprinkler.com

Sales Offices

Sales Fax

Corporate Offices

Internet Address



Recycled Paper

Revision lines indicate updated or new data.

EG. Printed in U.S.A 09/10

P/N 9999970146