

Reliable®

Model F156 EC Series Standard Response Extended Coverage Spray

Model F156 EC

Extended Coverage Sprinkler

- Pendent

Model F156 EC Recessed

Extended Coverage Sprinkler

- Recessed Pendent F1/F2/FP

Approval Organizations

1. Listed by Underwriters Laboratories, Inc. and Certified for Canada (cULus)

UL Listing Category

Sprinklers, Automatic & Open (VNIV)

Product Description

The F156 Extended Coverage Glass Bulb Sprinkler combines the durability of a standard sprinkler with the attractive low profile of a decorative sprinkler. Whether installed on exposed piping or in an office ceiling, it is functional and attractive.

Beautifully versatile is the description for the Reliable Model F156 Recessed Extended Coverage glass bulb sprinkler. Recessing the sprinkler enhances its already low profile decorative appearance, and facilitates a rapid and perfect installation.

Model F156 Recessed Extended Coverage escutcheon is highly adjustable. The two piece construction makes field installation a very easy and rapid task. This also allows ceiling panels to later be removed without shutting down the fire protection system, thus facilitating maintenance of above ceiling services.

The Model F156 Extended Coverage Sprinkler utilizes a frangible glass bulb. The glass bulb consists of an accurately controlled amount of special fluid hermetically sealed inside of a precisely manufactured glass capsule. This glass bulb is specially constructed to provide fast thermal response.

At normal temperatures, the glass bulb contains the fluid in both the liquid phase and in the vapor phase. The vapor phase can be seen as a small bubble. As heat is applied, the liquid expands forcing the bubble smaller and smaller as the liquid pressure increases. Continued heating forces the liquid to push out against the bulb, causing the glass to shatter, opening the waterway and allowing the deflector to distribute the discharging water.

The F156 Extended Coverage Sprinkler temperature rating is identified by the color of the glass bulb capsule as well as frame color where applicable.



Extended Coverage
Pendent



Recessed Extended Coverage
Pendent F1/F2



Recessed Extended Coverage
Pendent FP

Model F156 Extended Coverage Pendant Sprinkler

Deflector: EC Pendant

Installation Wrench: Model D Sprinkler Wrench

Approval Type: Extended Coverage - Light Hazard Occupancy

Table 1

Coverage Area					
Flow Rate		Pressure Nonimal		Max. Area Width x Length	
		K=5.6 (80)			
gpm	L/min	psi	bar	ft. x ft.	m x m
26	98.4	21.6	1,5	16 x 16	4.9 x 4.9
33	125.0	34.7	2,4	18 x 18	5.5 x 5.5
40	151.4	51.0	3,5	20 x 20	6.0 x 6.0



Extended Coverage Pendant

Installation Data:

Nominal Orifice	Thread Size	Nominal K Factor		Sprinkler Height	Temperature Rating		Sprinkler Identification Number (SIN)
		US	Metric		°F	°C	
½" (15mm)	½" NPT (R½)	5.6	80	2.25" (57mm)	135, 155	57, 68	RA2745

Model F156 Recessed Extended Coverage Pendant Sprinkler

Deflector: EC Pendant

Installation Wrench: Model GFR2 Sprinkler Wrench

Approval Type: Extended Coverage - Light Hazard Occupancy

Installation Data⁽¹⁾:

Nominal Orifice	Thread Size	Nominal K Factor		Sprinkler Height	Temperature Rating		Sprinkler Identification Number (SIN)
		US	Metric		°F	°C	
½" (15mm)	½" NPT (R½)	5.6	80	2.25" (57mm)	135, 155	57, 68	RA2745

⁽¹⁾ See Table 1 for Coverage Area.

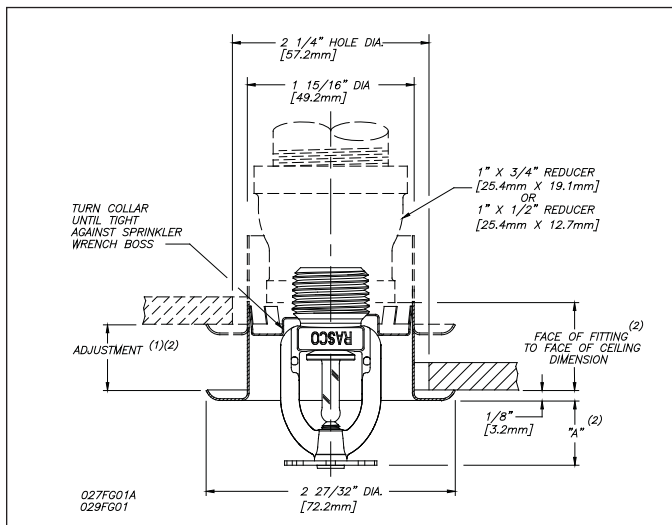

Model F156 EC F1/F2

Fig. 1

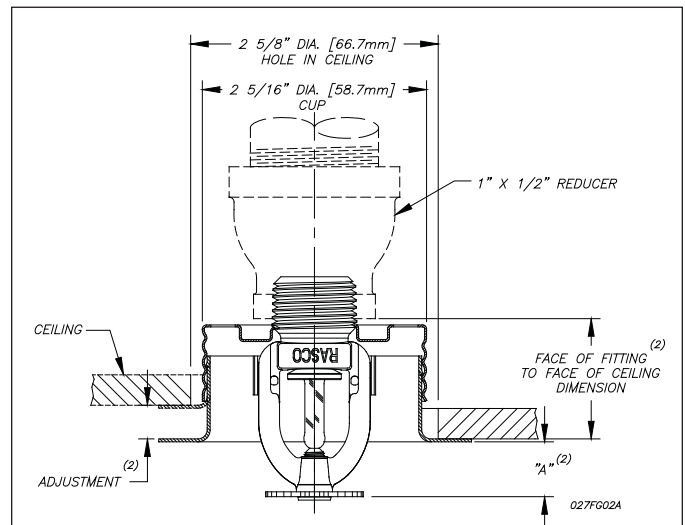

Model F156 EC FP

Fig. 2

⁽¹⁾ When installed directly into a tee, the escutcheon adjustment will be reduced.

⁽²⁾ Refer to escutcheon data table for dimensions.

Model F156 EC Pendent & F156 Recessed EC Pendent Sprinklers

Application

Model F156 EC and F156 EC Recessed sprinklers are used in fixed fire protection systems: Wet, Dry, Deluge or Preaction. Care must be exercised that the orifice size, temperature rating, deflector style and sprinkler type are in accordance with the latest published standards of the National Fire Protection Association or the approving Authority Having Jurisdiction.

Installation

Model F156 EC sprinklers are standard response sprinklers intended for installation as specified in NFPA 13. They must also be installed with the Model D Sprinkler Wrench specifically designed by Reliable for use with these sprinklers.

The Model F156 EC Recessed Sprinklers are to be installed with a maximum recess of $\frac{3}{4}$ inch (19mm). The Model F1, F2, and FP Escutcheons illustrated are the only recessed escutcheons to be used with the Model F156 EC Sprinklers. The use of any other recessed escutcheon will void all approvals and negate all warranties. When installing Model F156 EC Recessed Pendent and EC Pendent Sprinklers, use the Model GFR2 Sprinkler Wrench. Any other type of wrench may damage these sprinklers.

Glass bulb sprinklers have orange covers to protect the bulb during the installation process. REMOVE THIS PROTECTION ONLY AFTER THE SYSTEM HAS BEEN HYDROSTATICALLY TESTED AND, WHEN APPLICABLE, THE ESCUTCHEONS HAVE BEEN INSTALLED. RASCO wrenches are designed to install sprinklers when covers are in place.

Maintenance

The Models F156 EC and F156 EC Recessed Sprinklers should be inspected quarterly and the sprinkler system maintained in accordance with NFPA 25. Do not clean sprinklers with soap and water, ammonia or any other cleaning fluid. Remove any sprinkler which has been painted (other than factory applied) or damaged in any way. A stock of spare sprinklers should be maintained to allow quick replacement of damaged or operated sprinklers. Prior to installation, sprinklers should be maintained in the original cartons and packaging until used to minimize the potential for damage to sprinklers that would cause improper operation or non-operation.

Escutcheon Data

Escutcheon Model	Adjustment	"A" Dimension	Face of Fitting to Ceiling or Wall Dimension
F1	Max Recessed	1 $\frac{1}{2}$ " (38.1mm)	$\frac{3}{16}$ " - $\frac{15}{16}$ "
	Min Recessed	$\frac{3}{4}$ " (19.1mm)	(5m - 24mm)
F2	Max Recessed	1 $\frac{1}{2}$ " (38.1mm)	$\frac{3}{16}$ " - $\frac{11}{16}$ "
	Min Recessed	1" (25mm)	(5m - 17mm)
FP Push-on/ Thread-off	Max Recessed	$\frac{7}{16}$ " (11mm)	1 $\frac{1}{2}$ " (38.1mm)
	Min Recessed	$\frac{15}{16}$ " (24mm)	1" (25mm)

Standard Temperature Rating

Classification	Sprinkler Temperature		Maximum Ambient Temperature		Bulb Color
	°F	°C	°F	°C	
Ordinary	135	57	100	38	Orange Red
Ordinary	155	68	100	38	

Maximum Working Pressure

175 psi (12 bar)

100% Factory tested hydrostatically to 500 psi (34.5 bar)

Finishes ⁽¹⁾

Standard Finishes	
Sprinkler	Escutcheon
Bronze Chrome White or Black Polyester Coated	Brass Chrome White Painted
Special Applications Finishes	
Sprinkler	Escutcheon
Bright Brass ⁽²⁾ Black Plated Black Paint Off White Satin Chrome Lead Plated ⁽³⁾ Wax Coated ^{(3),(4)} Wax Over Lead ⁽³⁾	Bright Brass Black Plated Black Paint Off White Satin Chrome

⁽¹⁾ Other colors and finishes are available on special order. Consult factory for details.

⁽²⁾ 200°F (93°C) maximum.

⁽³⁾ 155°F to 200°F (68°C to 93°C) ratings only.

⁽⁴⁾ 286°F (141°C) sprinklers may be coated for ambient conditions not exceeding 150°F (66°C).

Note: Paint or any other coating applied over the factory finish will void approvals and warranties.

Ordering Information

Specify:

1. Sprinkler Model
2. Sprinkler Type
3. Orifice Size
4. Deflector Type
5. Temperature Rating
6. Sprinkler Finish
7. Escutcheon Finish (where applicable)

Note: When Model F156 EC Recessed Pendent Sprinklers are ordered, the sprinklers and escutcheons are packaged separately.

Reliable...For Complete Protection

Reliable offers a wide selection of sprinkler components. Following are some of the many precision-made Reliable products that guard life and property from fire around the clock.

- Automatic sprinklers
- Flush automatic sprinklers
- Recessed automatic sprinklers
- Concealed automatic sprinklers
- Adjustable automatic sprinklers
- Dry automatic sprinklers
- Intermediate level sprinklers
- Open sprinklers
- Spray nozzles
- Alarm valves
- Retarding chambers
- Dry pipe valves
- Accelerators for dry pipe valves
- Mechanical sprinkler alarms
- Electrical sprinkler alarm switches
- Water flow detectors
- Deluge valves
- Detector check valves
- Check valves
- Electrical systems
- Sprinkler emergency cabinets
- Sprinkler wrenches
- Sprinkler escutcheons and guards
- Inspectors test connections
- Sight drains
- Ball drips and drum drips
- Control valve seals
- Air maintenance devices
- Air compressors
- Pressure gauges/identification signs
- Fire department connection

The equipment presented in this bulletin is to be installed in accordance with the latest published Standards of the National Fire Protection Association, Factory Mutual Research Corporation, or other similar organizations and also with the provisions of governmental codes or ordinances whenever applicable.

Products manufactured and distributed by Reliable have been protecting life and property for over 90 years, and are installed and serviced by the most highly qualified and reputable sprinkler contractors located throughout the United States, Canada and foreign countries.

Manufactured by

Reliable[®]

The Reliable Automatic Sprinkler Co., Inc.
(800) 431-1588 Sales Offices
(800) 848-6051 Sales Fax
(914) 829-2042 Corporate Offices
www.reliablesprinkler.com Internet Address



Revision lines indicate updated or new data.

EG. Printed in U.S.A 12/10 P/N 999970387