

Reliable®

Model DDX-LP Dry Pipe Valve System 2" (50mm), 2½" (65mm), 3" (80mm) & 76 mm Sizes

Features

1. Differential-type valve, lightweight, dependable construction.
2. Low Air Pressurized System, 10 psi -to- 26 psi (0,7 bar -to- 1,8 bar).
3. Reset externally. Cover removal is not required.
4. No priming water requirement.
5. Hydrostatic testing with the clapper in the closed position.
6. No riser check valve required.
7. One main drain.
8. Drain valve to drain standing water column.
9. Valve latches in open position. No pressure operated relief valve is required.
10. Nitrogen pressurized system optional.
11. Grooved inlet and outlet connections.
12. Pressure rating of 250 psi (17,2 bar).

Listings & Approvals

Reliable Model DDX-LP Dry Pipe Valves, complete with trim that includes a Model LP Dry Valve Actuator, and only when used as the valve manufacturer's complete system are:

1. Listed by Underwriters Laboratories, Inc. and UL certified for Canada (cULus).
2. Certified by Factory Mutual Approvals (FM).

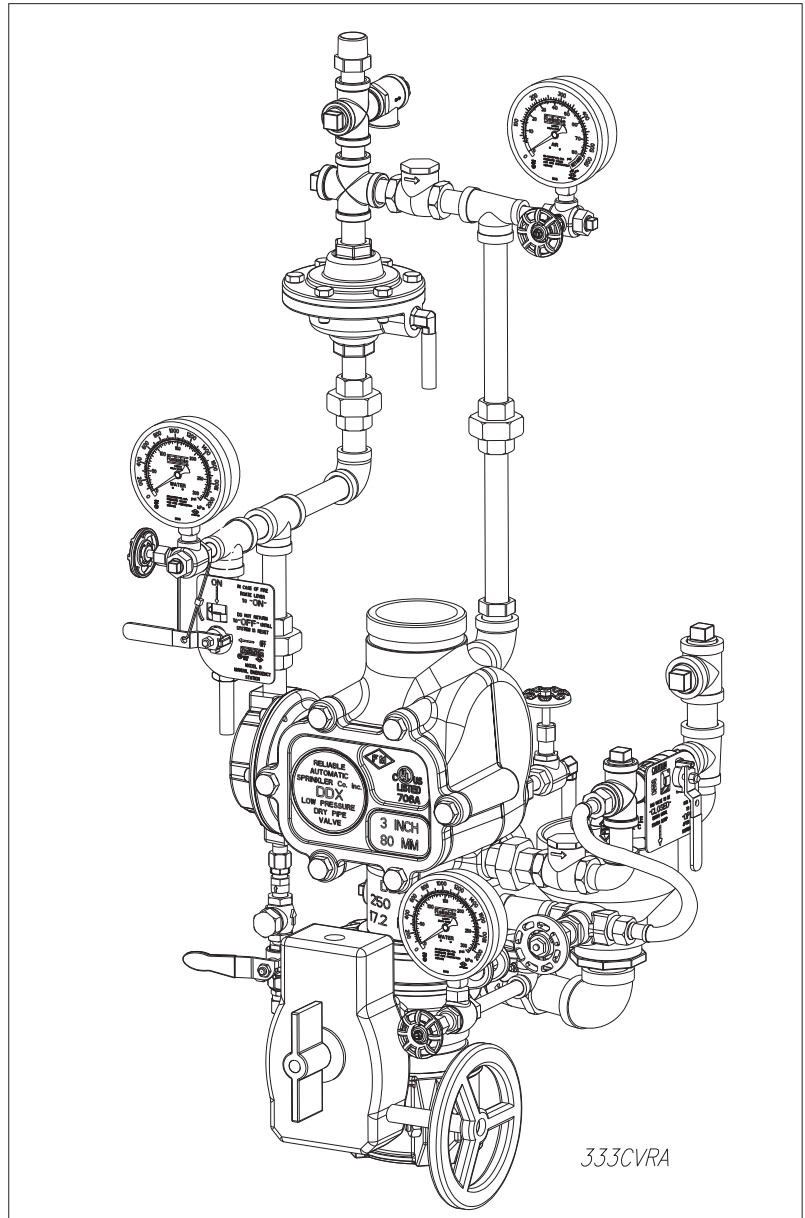

DDX VALVE CLAPPER IN "OPEN",
"CLOSED" AND "LATCHED" POSITIONS

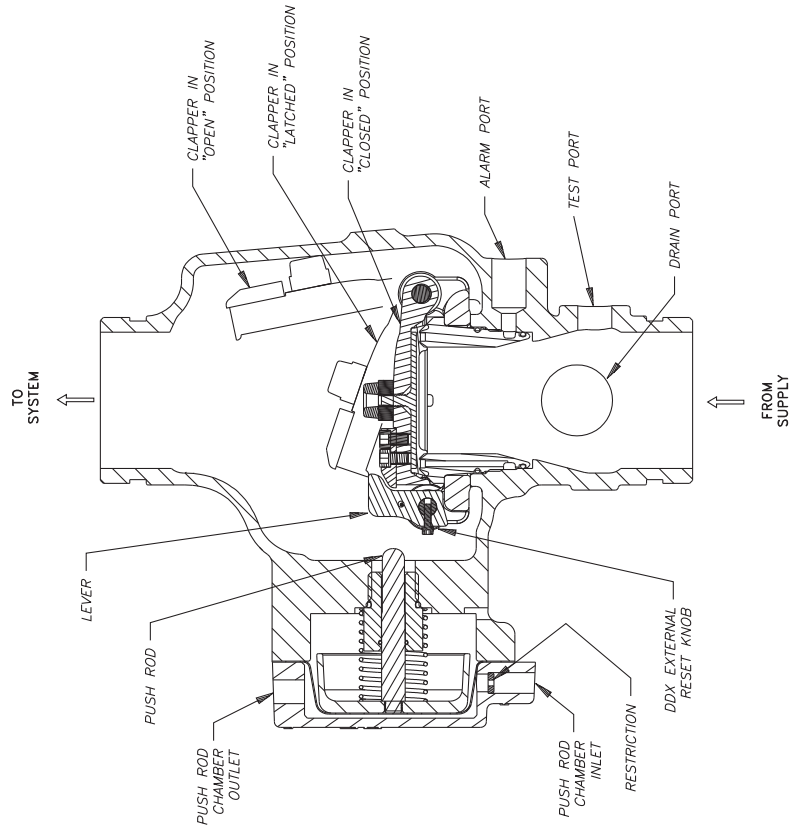

REAR VIEW OF MODEL
DDX DELUGE VALVE

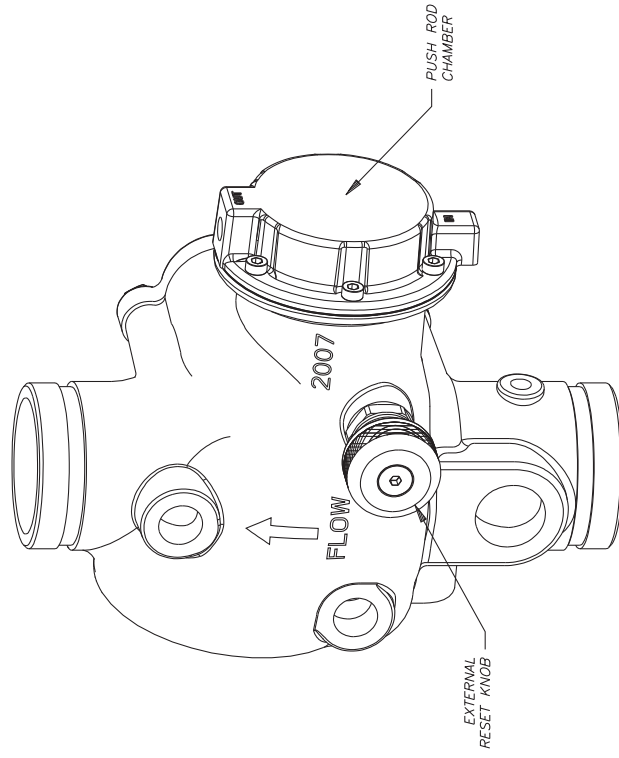

PUSH INWARD AND ROTATE KNOB CLOCKWISE TO RESET CLAPPER.
DO SO ONLY WHEN PUSH ROD CHAMBER IS UNPRESSURIZED (0 PSIG).

513FG01A

Fig. 1

General

The Reliable Model DDX-LP Dry Pipe Valve is a hydraulically operated, differential-type valve (see Fig 1.) designed for use as a primary control valve in a low pressure dry pipe valve system. The trim set used with the Model DDX-LP Dry Pipe Valve contains the Reliable Model LP Dry Valve Actuator releasing device. This Actuator allows the system's air or nitrogen pressure requirement to be considerably less than the available water supply pressure (see Table A). The following benefits are a direct result of lower air pressure:

1. In refrigerated area systems, lower air pressure decreases the possibility of ice plugs, which could impede or prevent the flow of water to sprinkler heads in the event of fire.
2. Lower air pressure (volume) will enable smaller capacity, lower cost dehydration equipment when it is required.
3. Lower air or nitrogen pressure can reduce water delivery time when the system actuates, and in some cases, may eliminate the need for an accelerator.
4. Low pressure requirements make the use of dry nitrogen gas, instead of air, practical even on larger systems. Resulting benefits include a lower-than-air dew point, which minimizes ice plugging of system lines, and enhances "user friendliness" during installation and operation.
5. System maintenance is simplified since priming water is not required and the Dry Pipe Valve can be reset externally without cover removal. This is accomplished by pushing in and turning the external reset knob at the rear of the Dry Pipe Valve (see Fig.1). This feature provides a significant system-restoration time advantage.

The Model DDX-LP Dry Pipe Valve's trim set (see Fig.2) provides all of the necessary equipment for connections to the pushrod chamber's inlet and outlet ports, the 1/4" (30mm) main drain, alarm devices, air supply, water supply and required pressure gauges. This trim set is available in individual parts, in time-saving, segmentally assembled kit forms, or fully assembled to the Model DDX-LP Dry Pipe Valve (with or without a control valve).

All the sizes of the Model DDX-LP Dry Pipe Valve trim sets may be equipped with the optional Reliable Model B1 Accelerator, trim kit P/N 651600003, (see Figs. 2 & 3). This device acts as an exhaustor which will hasten the operation of the Model LDX Dry Valve Actuator and minimize the water delivery time for the entire system.

System Operation

The Reliable Model DDX-LP Dry Pipe Valve is shown in both closed and open positions in Fig. 1. In the closed position, the supply pressure acts on the underside of the clapper and also on the push rod through the push rod chamber's inlet restriction. The resultant force due to the supply pressure acting on the push rod is multiplied by the mechanical advantage of the lever and is more than sufficient to hold the clapper closed against normal supply pressure surges.

When a sprinkler operates, there will be a loss of air or nitrogen pressure in the sprinkler system's piping which will cause the Model LP Dry Valve Actuator to open. The opening

of this device allows a releasing discharge of water from the pushrod chamber's outlet connection. Since the pressure cannot be replenished through the inlet restriction as rapidly as it is vented, the push rod chamber pressure falls instantaneously. When the push rod chamber pressure approaches approximately one-third of the supply pressure, the upward force of the supply pressure acting beneath the clapper overcomes the lever-applied force thereby opening the clapper.

Once the clapper has opened, the lever acts as a latch, preventing the clapper from returning to the closed position. Water from the supply flows through the Dry Pipe Valve into the system piping. Water also flows through the Dry Pipe Valve's alarm outlet to the alarm devices.

After system shutdown, resetting the Model DDX-LP Dry Pipe Valve is quite simple. Doing so only requires pushing in and turning the reset knob at the rear of the valve (see Fig. 1). The external reset feature of the Model DDX-LP Dry Pipe Valve provides a means for simple, economical system testing, which is one essential facet of a good maintenance program. The external reset feature does not, however, eliminate another important facet of good maintenance, namely, periodic cleaning and inspection of the internal valve parts.

In the event that water builds up inside the valve due to condensate from the air supply system or water left inside from valve system testing, a drain is available for venting. After closing the main supply valve, a small valve over the drain cup can be opened slightly until the water inside the valve body and the main pipe column has drained. See the section titled "Draining Excess/Condensate Water From System" in this bulletin for the detailed procedure.

The Model B Manual Emergency Station (see Fig. 4) is also included in the Model DDX-LP Dry Pipe Valve trim set. It consists of an aluminum nameplate mechanically attached to a ball valve. The valve handle in its OFF position is guarded against accidental turning to the ON position (and system discharge) by a nylon cable tie provided with each trim kit. The cable tie is inserted, as shown in Fig. 4, after the system has been restored for operation. The nylon cable tie is designed to allow, in case of an emergency, forceful turning of the valve handle to the ON position. As an alternative to the Model B Hydraulic Manual Emergency Station, the Model A Hydraulic Manual Emergency Pull Box (see Reliable Bulletin 506) is also available and can be provided as an option.

Whenever ambient temperature conditions are high, the water temperature in the Model DDX-LP Dry Pipe Valve's pushrod chamber could possibly increase, thereby increasing the pressure in the chamber to values exceeding the rated pressure of the system. In an indoor installation where standard room temperatures are exceeded, a pressure relief kit may be needed. Pressure relief kit, P/N 6503050001, can be installed into the pushrod chamber's releasing line to limit the pressure to 175 psi (12,1 bar).

Hydrostatic Testing of DDX Valves and DDX Systems

As required by NFPA 13, fire sprinkler systems with working pressures up to and including 150 psi are to be hydrostatically tested at a water pressure of 200 psi and maintain that pressure without loss for two hours. Fire sprinkler systems with working pressures above 150 psi are required to be hydrostatically tested at 50 psi above the system working pressure and maintain that pressure without loss for two hours. In addition to the hydrostatic tests described above,

dry pipe and double interlock preaction systems require an additional low pressure air test. In some cases, hydrostatic testing (in accordance with the NFPA 13 requirements noted above) will result in pressures that exceed the working pressure of the valve and trim kit for the two-hour test period.

The valve and applicable trim kit have been tested, approved and listed under these conditions and as such, hydrostatic testing in accordance with NFPA 13 is acceptable. In addition, the clapper can remain in the closed position and the trim kit need not be isolated, as each has been designed to withstand hydrostatic testing as required by NFPA 13.

Hydrostatically testing the valve and trim to pressures higher than their rating is limited to the hydrostatic test as referenced by NFPA13. It does not address the occurrence(s) of a "water hammer" effect, which can indeed damage the valve. A "water hammer" in the water supply piping of the valve can create pressures in excess of the rated pressure and should be avoided by all necessary means. This condition may be created from improper fire pump settings, underground construction work, or an improper venting of trapped air in the water supply piping.

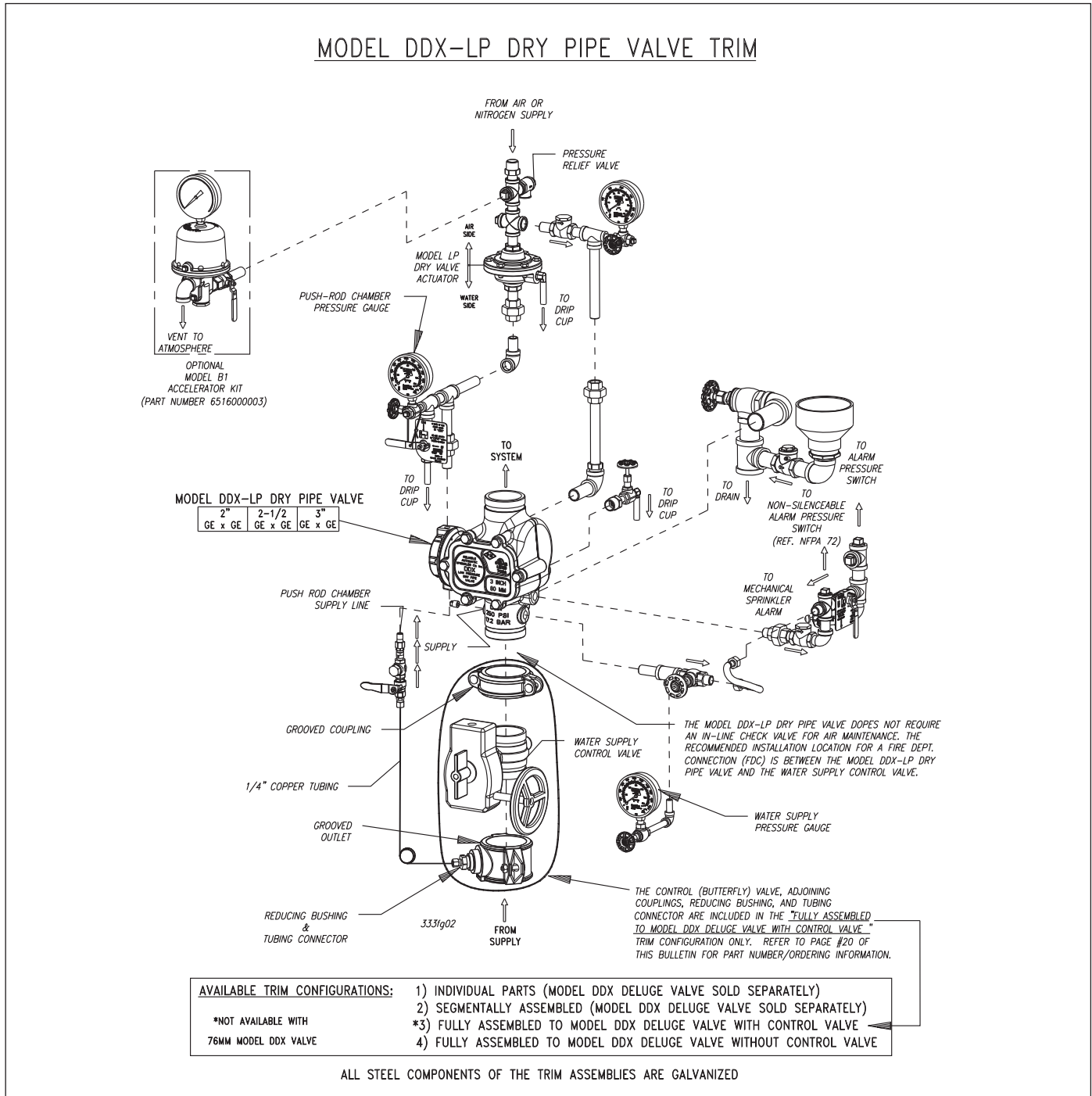

Fig.2

RELIABLE MODEL B1 ACCELERATOR KIT (P/N 6516000003)

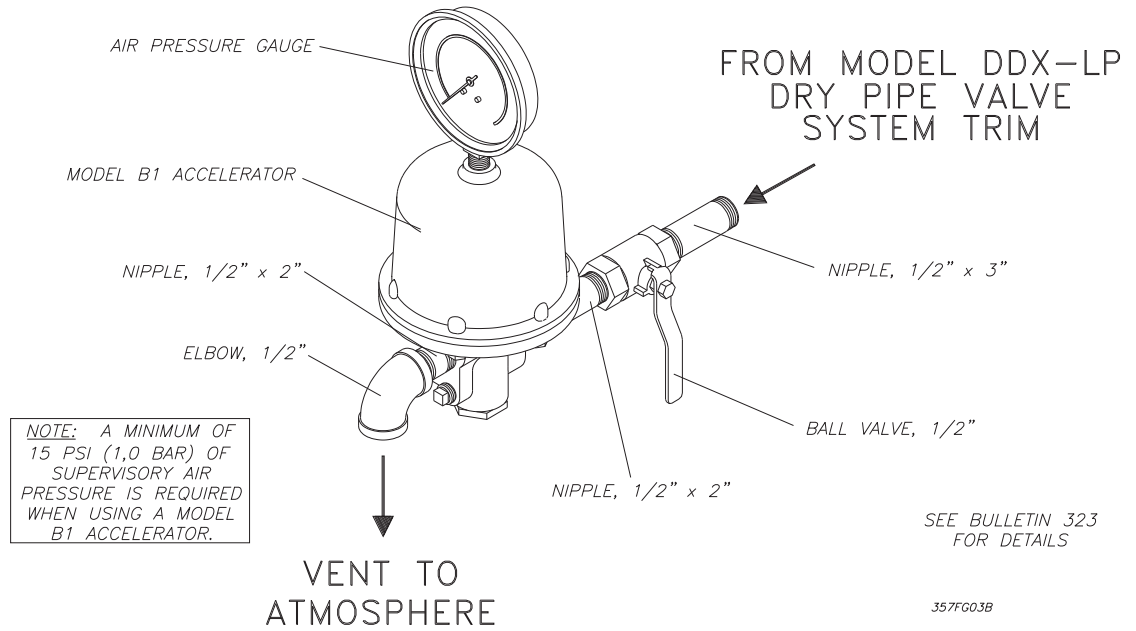

Fig. 3

MODEL B HYDRAULIC MANUAL EMERGENCY STATION

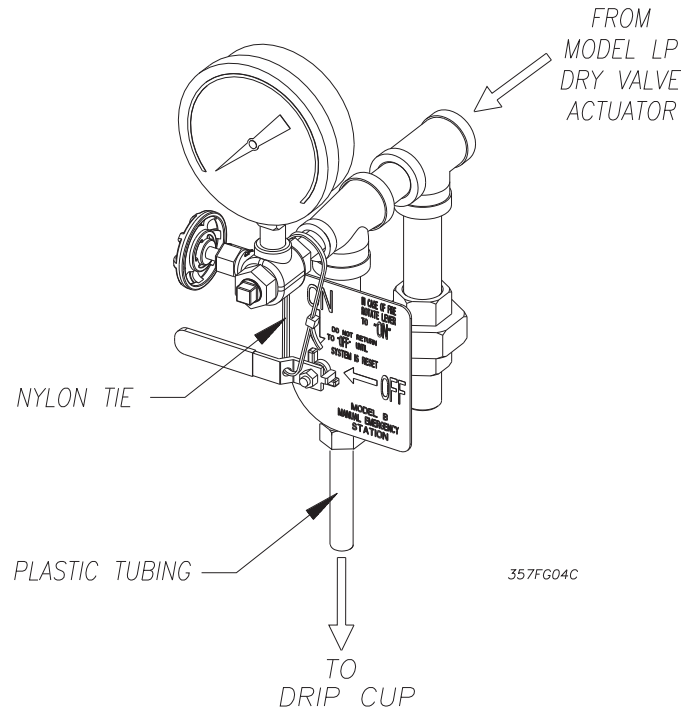

Fig. 4

Technical Data

Reliable Model DDX-LP Dry Pipe Valves, with associated trim, sizes 2" (50mm), 2½" (65mm), 3" (80mm) and 76mm, are rated for use at a minimum water supply pressure of 20 psi (1,4 bar) and a maximum water supply pressure of 250 psi (17,2 bar). Water supplied to the inlet of the valve and to the pushrod chamber must be maintained between 40°F (4°C) and 140°F (60°C).

The following list of technical bulletins pertains to valves and devices that may be used in this Dry Pipe Valve system:

Deluge/Dry Pipe Valve	Reliable 512/513
Mechanical Sprinkler Alarm	Reliable 612/613
Pressure Maintenance Device	Reliable 250/251
Nitrogen Regulating Device	Reliable 253
Model B1 Accelerator Trim Kit	Reliable 323
Hydraulic Emergency Station (Model A)	Reliable 506
Low Air Pressure Alarm Switch	System Sensor A05-0177
Waterflow Pressure Alarm Switch	System Sensor A05-0176

Model DDX-LP Dry Pipe Valve Description

- Rated working pressure:
Valve & System - 250 psi (17,2 bar)
- Factory tested to a hydrostatic pressure of 500 psi (34,5 bar). (Valve only)
- End and trim connections:
 - ANSI/AWWA C606 grooved inlet and outlet
 - Threaded openings Per ANSI B 2.1

Groove Dimensions				
Valve Size	Outlet Diameter	Groove Diameter	Groove Width	Outlet Face to Groove
2" (50mm)	2.375" (60mm)	2.250" (57mm)	1½" (9mm)	5⁄8" (16mm)
2.5" (65mm)	2.875" (73mm)	2.720" (69mm)		
3" (80mm)	3.500" (89mm)	3.344" (85mm)		
76mm	3.000" (76mm)	2.845" (72mm)		

- Valve exterior's color:

Valve Size	Color
2" (50mm) 2.5" (65mm) 3" (80mm)	Black
76mm	Red

- Face to face dimensions:
 - 2" (50mm) — 12½" (318 mm)
 - 2.5" (65mm) — 12½" (318 mm)
 - 3" (80mm) — 12½" (318 mm)
 - 76mm — 12½" (318 mm)

- Shipping weight:

Valve Size	Weight
2" (50mm), 2.5" (65mm) 3" (80mm) & 76mm	34 lb. (15 kg)

- Friction loss (Expressed in equivalent length of Schedule 40 pipe, based on Hazen & Williams formula with C=120 and a flow velocity of 15ft/sec (4.6 m/sec)):

Valve Size	Equivalent Length
2" (50 mm)	4.4' (1.3 m)
2.5" (65 mm)	6.0' (1.8 m)
3" (80 mm)	12.6' (3.8 m)
76 mm	7.7' (2.3 m)

At 15 ft/sec

7 Installation position: Vertical

System Air or Nitrogen Pressure Requirements

The system trim includes gauges to read the pneumatic and water pressures of Model LP Dry Valve Actuator. Table A specifies the air or nitrogen pressure level to be applied to the Actuator. Reliable Model A-2 Pressure Maintenance Device (see Reliable Bulletins 250 & 251) which is sold separately, automatically provides a safeguard against pressure leaks in the sprinkler piping, and properly restrict the flow of makeup air. When the optional Model B1 Accelerator is used, a Model A-2 Pressure Maintenance Device and a tank-mounted air compressor are required (see Fig.5). Also, when a Model B1 Accelerator is used, to expedite water-delivery time, the pneumatic pressure must not be less than 15 psi (1,0 bar).

Whenever multiple dry systems are installed at the same location, each dry system is to have its own Model A-2 Pressure Maintenance Device installed for individual maintenance of air pressure (Refer to the 2007 Edition of NFPA 13, section 7.2.6.5.3).

Table A

Water Pressure psi (bar)	Pneumatic Pressure to be Pumped into Sprinkler System, psi (bar)	
	Not Less Than	Not More Than
20 (1,4)	10 (0,7)	14 (0,9)
50 (3,4)	12 (0,8)	16 (1,1)
75 (5,2)	13 (0,9)	17 (1,2)
100 (6,9)	15 (1,0)	19 (1,3)
125 (8,6)	16 (1,1)	20 (1,4)
150 (10,3)	17 (1,2)	21 (1,4)
175 (12,1)	18 (1,2)	22 (1,5)
200 (13,8)	19 (1,3)	23 (1,6)
225 (15,5)	21 (1,5)	25 (1,7)
250 (17,2)	22 (1,5)	26 (1,8)

Note: During system set-up, a higher pneumatic pressure may be required in order to properly set the Model LP Dry Valve Actuator.

Nitrogen used in refrigerated area systems minimizes a possibility of ice build-up and blockage inside the system piping that could inhibit proper system operation. The calculated nitrogen supply in lbs (kg) to pressurize various system capacities to 10 psi (0,7 bar) at different freezer temperatures is as follows:

System Capacity Gal. (L)	Freezer Temperature, °F (°C)					Approx. Fill Time (min.)*
	20°(-6.7°)	0°(-18°)	-20°(-29°)	-40°(-40°)	-60°(-51°)	
250 (946)	1.90 (0.86)	1.90 (0.86)	2.00 (0.90)	2.10 (0.95)	2.20 (1.00)	1
500 (1891)	3.64 (1.65)	3.80 (1.72)	4.00 (1.81)	4.20 (1.91)	4.40 (2.00)	2
750 (2840)	5.50 (2.50)	5.70 (2.60)	6.00 (2.72)	6.30 (2.86)	6.60 (3.00)	3
1,000 (3785)	7.30 (3.30)	7.60 (3.44)	8.00 (3.62)	8.33 (3.78)	8.80 (4.00)	4

Note: To obtain required nitrogen supply (lbs.) for 15 psi (1,0 bar) or 22 psi (1,5 bar), multiply the tabulated valves by a factor of 1.5 or 2.2 respectively.

(1 bar = 100 kPa)

* When filled with the Reliable Model A-2 Pressure Maintenance Device having the bypass valve open.

Ordering Information

Specify:

- **Valve Model & Size** — 2" (50 mm) Model DDX-LP Dry Pipe Valve (P/N 6103022000), 2½" (65mm) Model DDX-LP Dry Pipe Valve (P/N 6103022500), 3" (80mm) Model DDX-LP Dry Pipe Valve (P/N 6103030000), 76 mm Model DDX-LP Dry Pipe Valve (P/N 6103027600).
- **Trim** — The trim set is available in individual parts, in time-saving segmentally assembled kit forms, or fully assembled to the Model DDX-LP Dry Pipe Valve (with or without a control valve).

Trim Configurations	Trim Part Numbers			
	2" (50 mm)	2.5" (65 mm)	3" (80 mm)	76mm Valve
Fully Assembled to DDX Valve w/ Control Valve	6505020020	6505022520	6505030020	Not Available
Fully Assembled to DDX Valve w/o Control Valve	6505020021	6505022521	6505030021	6505027621
Segmentally Assembled (DDX Valve Sold Separately)	6505040504			
Individual Parts (DDX Valve Sold Separately)	6505040503			

Note: For metric installations, a 1-1/4" NPT x R2, ISO 7/1 x Close Nipple (Reliable P/N 98543403) is sold separately as an adapter for the single drain outlet of the trim(s).

• Additional Equipment

Component Part	Mfgr.	Description	Technical Bulletin
Water Supply Control Valve	Select	Ball Valve, 2" (50mm)	-
		Butterfly Valve 2½" (65mm), 3" (80mm), 76mm	-
Tamper Switch (Optional) for OS&Y Valve	B	Model OS&Y2	System Sensor A05-0196
(Optional) for Butterfly Valve		Model P1BV2	System Sensor A05-0197
Deluge / Dry Valve	A	Model DDX, 2" (50mm), 2½" (65mm), 3" (80mm), 76mm	Reliable 512 / 513
Dry Pipe Valve System	A	Refer to Parts in this Bulletin	Reliable 333 / 334
Waterflow Alarm Pressure Switch	B	Model EPS10-2 (DPDT, UL, FM)	System Sensor A05-0176
		Model EPSA10-2 (DPDT, ULC)	
Low Air Alarm Pressure Switch	B	Model EPS40-2 (DPDT, UL, FM)	System Sensor A05-0177
		Model EPSA40-2 (DPDT, ULC)	
Mechanical Alarm (Optional)	A	Model C	Reliable 612 / 613
Manual Emergency Station	A	Model A Hydraulic (Pilot Line) Type	Reliable 506
Sprinklers	A	Closed Type	Reliable 110, 117, 131, 136, etc.
Air Compressor	C	Tank Mounted	Gast H-10-0801
Pressure Maintenance Device	A	Model A-2	Reliable 250 / 251
* Accelerator Kit	A	Model B1	Reliable 323
Nitrogen Regulating Device	A	Regulator with Optional Low Air Pressure Switch	Reliable 253

*If the optional Model B1 Accelerator is used, a tank-mounted air compressor and an A-2 pressure maintenance device must be provided. Additionally the use of a tank-mounted air compressor helps to eliminate on/off compressor cycling that may occur as a result of small leakage in the air line between the pressure maintenance device and the 1/2" check valve, as well as due to ambient temperature changes in the system piping.

System Equipment Manufacturers

- (A) The Reliable Automatic Sprinkler Co., Inc.
- (B) System Sensor
- (C) Gast Manufacturing Corp.

Installation Dimensions

Installation Dimensions in Inches (mm)																
VALVE	A	B	C	*D	E	F	G	H	J	K	L	M	N	P	Q	R
2" (50mm)																
2½" (65mm)	7 ¾	6 ½	9 ¼	12 ½	25 ¼	39	28 ½	5 ½	8 ¼	3 ½	5 ¼	9 ¼	2 ¼	3 ¼	5	5 ¼
3" (80mm) & 76mm	(197)	(165)	(235)	(318)	(654)	(990)	(724)	(140)	(210)	(89)	(133)	(248)	(57)	(95)	(127)	(146)

*** Total take out dimension for Fully Assembled to DDX Valve w/Control Valve Configurations:**

2" - 20⁷/₃₂", 2½" & 3" - 17²⁷/₃₂" , 76 mm - N/A.

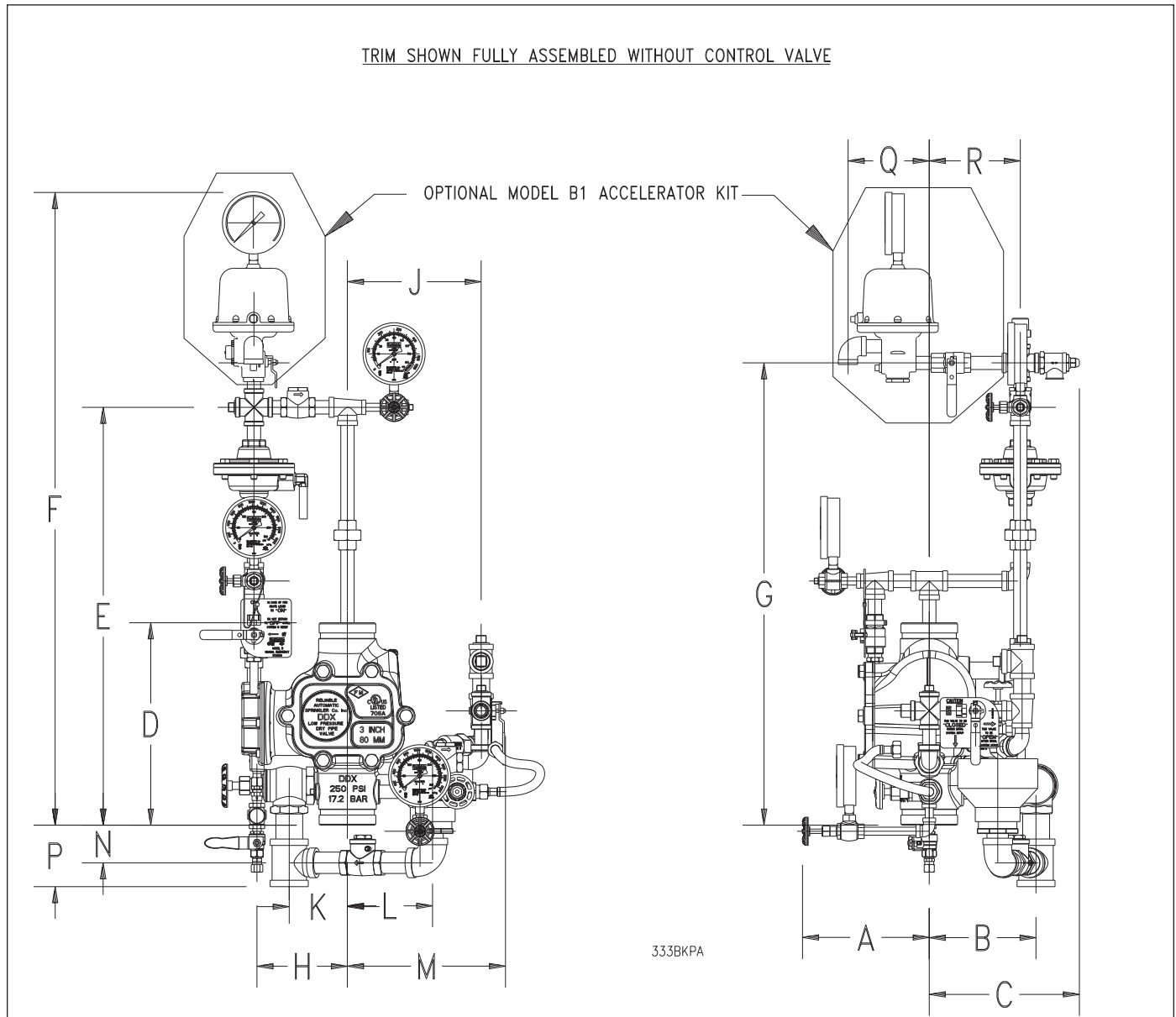

The equipment presented in this bulletin is to be installed in accordance with the latest published Standards of the National Fire Protection Association, Factory Mutual Research Corporation, or other similar organizations and also with the provisions of governmental codes or ordinances whenever applicable.

Products manufactured and distributed by Reliable have been protecting life and property for over 90 years, and are installed and serviced by the most highly qualified and reputable sprinkler contractors located throughout the United States, Canada and foreign countries.

Manufactured by

Reliable®

The Reliable Automatic Sprinkler Co., Inc.
 (800) 431-1588 Sales Offices
 (800) 848-6051 Sales Fax
 (914) 829-2042 Corporate Offices
 www.reliablesprinkler.com Internet Address



Revision lines indicate updated or new data.
 EG. Printed in U.S.A 03/10 P/N 9999970328