



## EPS120-1 and EPS120-2 Supervisory Pressure Switches

*System Sensor EPS120 Series switches are designed to supervise system air pressure in pipes or pressure tanks, as well as water or air pressure supplies of automatic water control valves.*



### Features

---

- Pressure adjustment wheel, no special tools required
- Field-adjustable pressure sensitivity
- Factory set for use in a nominal 115 psi system
- Reinforced diaphragm resists pressure spikes
- Two conduit entrances provided
- NEMA 4 rated

The EPS120-1 has a single SPDT switch. The EPS120-2 model contains two SPDT switches. The EPS120 Series features field-adjustable pressure sensitivity to provide an alarm response between 10 and 200 psi. All models are factory set for use in a nominal 115 psi system. The EPS120-1 is factory set to respond at 105 psi at decreasing pressure. The EPS120-2 is factory set to respond at 125 psi on rising pressure and 105 psi on decreasing pressure. The pressure adjustment wheel requires no special tools and does not affect switch synchronization on the EPS120-2.

### Agency Listings

---



# EPS120 Series Specifications

## Architectural/Engineering Specifications

Model shall be an EPS120-1 or EPS120-2 pressure-type waterflow switch as manufactured by System Sensor of St. Charles, IL. They shall be installed on the sprinkler system with connection as shown on the drawings and/or as specified herein. Pressure switches shall be of the bellows-activated type. Switches shall have a maximum service pressure rating of 250 psi and shall be adjustable from 10–200 psi. There shall be one (1) or two (2) SPDT contacts rated at 10.0 Amp @ 125/250 VAC and 2.5 Amp @ 6/12/24 VDC. The contractor shall furnish and install, where indicated on the plans, pressure switches according to appropriate NFPA standards. Switches shall be provided with a 1/2" NPT male pressure connection to be connected into the air supply line on the system side of any shut-off valve. Switches shall provide 1 knockout type and 1 open hole for 1/2" conduit fitting attachment and a ground screw provision for electrical grounding. The switch enclosure shall be weatherproof and carry a UL 4x/NEMA 4 rating when used with proper electrical fittings and conduit. The cover shall incorporate tamper-resistant screws. The unit shall be listed by Underwriters Laboratories, Inc. and Underwriters Laboratories of Canada, Inc. and approved by Factory Mutual.

## Physical/Operating Specifications

<b>Maximum Operating Pressure</b>	250 psi	<b>Differential</b>	Approximately 3 psi @ 10 psi, 9 psi @ 200 psi
<b>Pressure Connection</b>	1/2" NPT male	<b>Enclosure</b>	Rated UL 4x, NEMA 4 for indoor or outdoor use
<b>Maximum Adjustment Pressure Range</b>	10 to 200 psi	<b>Dimensions</b>	5.120" H x 3.325" W x 4.250" L (13.0 cm x 8.4 cm x 10.8 cm)
<b>Operating Temperature Range</b>	Indoor or outdoor use –40°F to 160°F (–40°C to 71°C)	<b>Cover Tamper Switch</b>	UL Models: Optional P/N 546-8000 ULC Models: Factory Installed
<b>Factory Setting</b>	EPS120-1 operates at decreasing pressure at 105 psi; EPS120-2 operates at increasing pressure at 125 psi and decreasing pressure at 105 psi	<b>Service Use</b>	Automatic Sprinkler: NFPA 13 One- or Two-Family Dwelling: NFPA 13D Residential Occupancies up to 4 Stories: NFPA 13R National Fire Alarm Code: NFPA 72
<b>Switch Contact Ratings</b>	EPS120-1: One set SPDT (Form C) EPS120-2: Two sets SPDT (Form C) 10.0 A, 1/2 HP @ 125/250 VAC 2.5 A @ 6/12/24 VDC	<b>Shipping Weight</b>	1.2 lbs. (.54 Kg)
		<b>Warranty</b>	3 years

## Pressure Switch Basic Dimensions

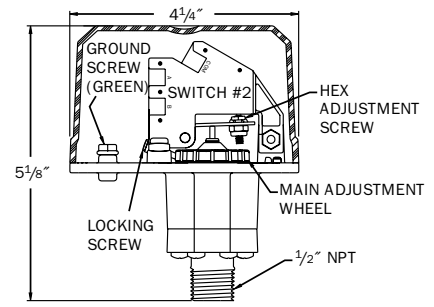

## Electrical Connections

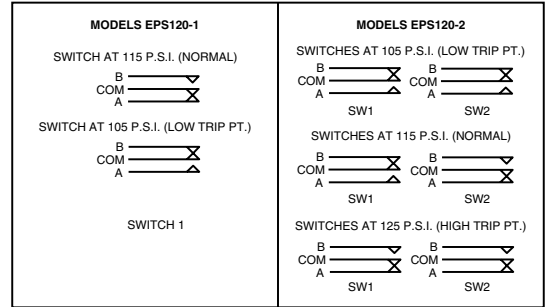

## Typical Sprinkler Applications

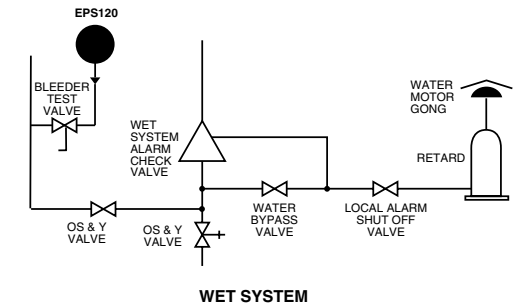
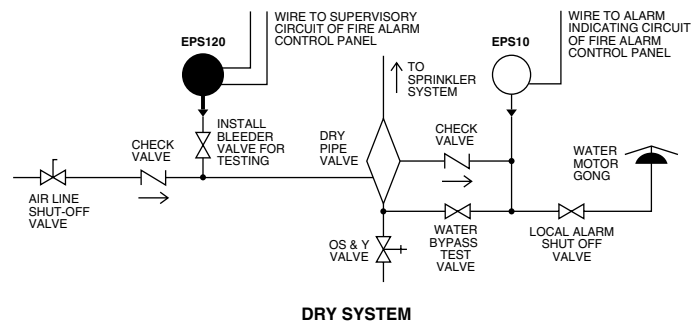

## Ordering Information

UL Model No.	ULC/Canadian Model No.	Description
EPS120-1	EPSA120-1	Low-pressure supervisory switch, one SPDT, 10–200 PSI
EPS120-2	EPSA120-2	High/low-pressure supervisory switch, two SPDT, 10–200 PSI

Replacement Parts			
S07-66-XX	Replacement tamper screws for cover of EPS	546-8000	Cover tamper switch for EPS Series
WFDW	Replacement tamper-proof wrench for cover of EPS		



3825 Ohio Avenue • St. Charles, IL 60174  
Phone: 800-SENSOR2 • Fax: 630-377-6495

©2009 System Sensor.  
Product specifications subject to change without notice. Visit systemsensor.com for current product information, including the latest version of this data sheet.  
A05-0939-006 • 2/09 • #2041