



## EPS40-1 AND EPS40-2 Supervisory Pressure Switches

*System Sensor EPS40 Series switches are designed for use in dry pipe systems or pressure tanks and water pressure supplies of automatic water control valves.*



### Features

- Sensitivity adjustment wheel, no special tools required
- Reinforced diaphragm resists pressure spikes
- Two conduit entrances
- Both one- and two-switch models available

### Agency Listings



S739



118F/01



0X0A7.AY



CS169

VdS

G4020028



7770-1209:147

MEA  
approved

167-93-E

The EPS40-1 has a single SPDT switch while the EPS40-2 model contains two SPDT switches. The EPS40 Series features field adjustable pressure sensitivity to provide an alarm response between 10 and 100 psi. All models are factory set for use in a nominal 40 psi system. The EPS40-1 is factory set to respond at 30 psi at decreasing pressure while the EPS40-2 is factory set to respond at 50 psi on rising pressure and 30 psi at decreasing pressure. The pressure adjustment wheel requires no special tools and does not affect switch synchronization on the EPS40-2. The EPS40-1 and EPS40-2 supervisory pressure switches are NEMA 4 rated.

### Specifications, EPS40-1 and EPS40-2

#### Architectural/Engineering Specifications EPS40-1 (SPDT), EPS40-2 (2/SPDT)

Model shall be an EPS40-1 or EPS40-2 pressure type waterflow switch as manufactured by System Sensor of St. Charles, IL. They shall be installed on the sprinkler system with connection as shown on the drawings and/or as specified herein. Pressure switches shall be of the bellows-activated type. Switches shall have a maximum service pressure rating of 250 psi and shall be adjustable from 10 – 100 psi. There shall be one (1) or two (2) SPDT contacts rated at 10.0 Amp @ 125/250 VAC and 2.5 Amp @ 6/12/24 VDC. The contractor shall furnish and install, where indicated on the plans, pressure switches according to appropriate NFPA standards. Switches shall be provided with a ½" NPT male pressure connection to be connected into the air supply line on the system side of any shut-off valve. Switches shall provide 1 knockout type and 1 open hole for ½" conduit fitting attachment and a ground screw provision for electrical grounding. The switch enclosure shall be weatherproof and carry a UL 4x/NEMA 4 rating when used with proper electrical fittings and conduit. The cover shall incorporate tamper-resistant screws. The unit shall be listed by Underwriters Laboratories, Inc., the California State Fire Marshal, MEA, CSFM, LPCB, VdS and approved by Factory Mutual.

## Specifications, EPS40-1 and EPS40-2 (continued)

Physical/Operating Specifications			
<b>Maximum Operating Pressure</b>	250 psi	<b>Operating Temperature Range</b>	Indoor or outdoor use: -40°F to 160°F (-40°C to 71°C)
<b>Maximum Adjustment Pressure Range</b>	10 to 100 psi	<b>Cover Tamper Switch</b>	UL Models: Optional P/N 546-8000 ULC Models: Factory Installed
<b>Differential</b>	Approximately 3 psi @ 10 psi, 6 psi @ 100 psi	<b>Enclosure</b>	Rated UL 4x, NEMA 4 for indoor or outdoor use
<b>Factory Setting</b>	EPS40-1 operates at decreasing pressure at 30 psi EPS40-2 operates at increasing pressure at 50 psi and decreasing pressure at 30 psi	<b>Shipping Weight</b>	1.2 lbs. (.54 Kg)
<b>Switch Contact Ratings</b>	EPS10-1: One set SPDT (Form C) EPS10-2: Two sets SPDT (Form C) 10.0 A, ½ HP @ 125/250 VAC 2.5 A @ 6/12/24 VDC	<b>Service Use</b>	Automatic Sprinkler: NFPA 13 One or Two Family Dwelling: NFPA 13D Residential Occupancies up to 4 Stories: NFPA 13R National Fire Alarm Code: NFPA 72
<b>Pressure Connection</b>	½" NPT male	<b>Warranty</b>	3 years
<b>Dimensions</b>	5.12" H x 3.325" W x 4.250" L (13.0 cm x 8.4 cm x 10.8 cm)		

## Typical Sprinkler Applications

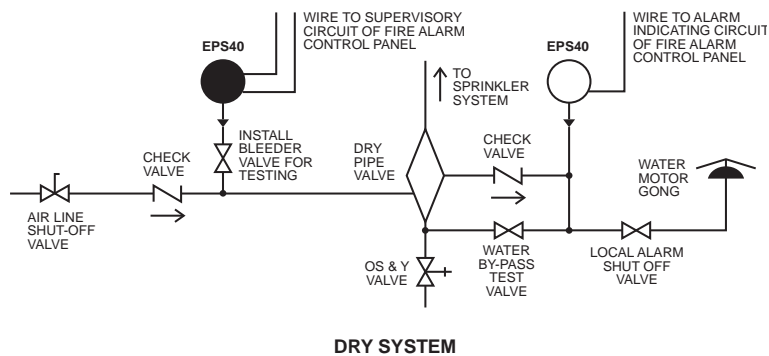

## Electrical Connections

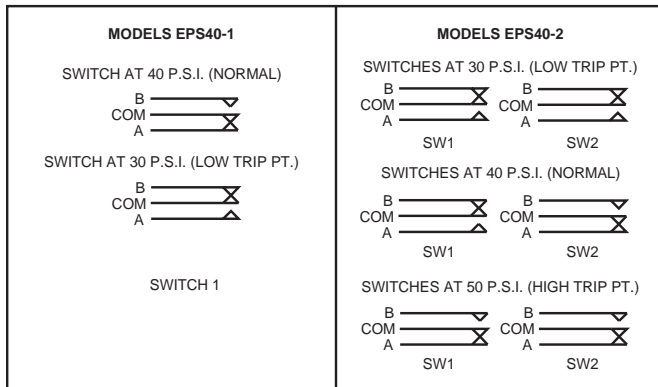

## Pressure Switch Basic Dimensions

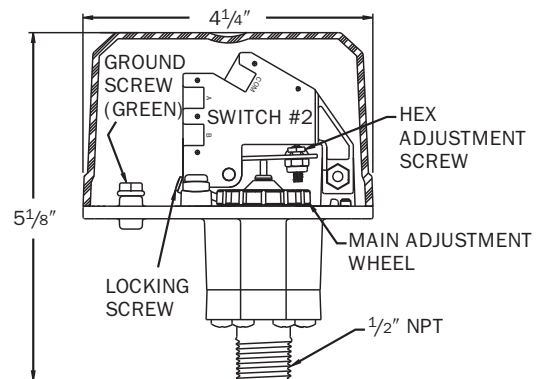

## Ordering Information

Part No.	Description
EPS40-1	Low Pressure Supervisory Switch, One SPDT, 10-100 PSI
EPS40-2	High/Low Pressure Supervisory Switch, Two SPDT, 10-100 PSI
EPSA40-1	Low Pressure Supervisory Switch, One SPDT, 10-100 PSI (ULC Model)
EPSA40-2	High/Low Pressure Supervisory Switch, Two SPDT, 10-100 PSI (ULC Model)
<b>Replacement Parts</b>	
S07-66-XX	Replacement Tamper Screws for Cover of EPS
WFDW	Replacement Tamper Proof Wrench for Cover of EPS
546-8000	Cover Tamper Switch for EPS Series



3825 Ohio Avenue • St. Charles, IL 60174  
Phone: 800-SENSOR2 • Fax: 630-377-6495

©2006 System Sensor.  
Product specifications subject to change without notice. Visit [systemsensor.com](http://systemsensor.com) for current product information, including the latest version of this data sheet.  
A05-0177-010 • 9/06 • #1676